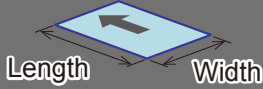

7-1 Specifications

Model	RD-4055	
Sheet Feeding System	Air Suction Feed Belt	
Sheet Size (Before processing)	Max. W400 x L550 mm / W15.74" x L21.65"	
	Min. W200 x L275 mm / W7.88" x L10.83"	
Cut Product Size	With separator (see note 1)	Max. W376 x L530 mm / W14.8" x L20.8"
		Min. W50 x L80 mm / W1.97" x L3.15"
	Without separator (see note 2) (with nicks)	Max. W384 x L530 mm / W15.1" x L20.8"
		Min. Depending on die shape
Processed Material	Normal paper, Coated paper, Cardboard The sheets below cannot be processed: Sheet whose back side is laminated (cover with polypropylene) Plastic film	
Material Thickness	127.9 to 400gsm Die Cutting: Max. 0.5 mm / 0.019" (In case of blade height: 0.8 mm / 0.031") Max. 0.3 mm / 0.001" (In case of blade height: 0.6 mm / 0.023") Creasing: Max. 0.4 mm / 0.015" (In case of blade height: 0.8 mm / 0.031")	
Feeder Stack Height	500 mm / 19.68"	
Available Cutting Area	Max. W376 x L530 mm / W14.8 x L20.8"	
Die Size - Upper Die	Max. W400 x L560 mm / W15.74 x L22.04"	
	Min. W160 x L100 mm / W6.30" x L3.94"	
Upper Cutting Blade Height	0.6 or 0.8 mm / 0.0236 or 0.0315"	
Gripping width for Repeat Die Cutting	170 mm / 6.69"(includes the cut product at least)	
Production Speed	Die cut roller 6,000 cycles per hour (When the ST-4055 is connected, the number of processing sheet is 3,000 sheets per hour.)	
Bucket Receiving Tray Capacity	80 mm / 3.15" when using the BT-4055	
Voltage/Frequency	Single Phase 200 to 240 V, 50 / 60 Hz	
Rated Current	With separator (see note 1)	200 to 240 V, 7.5 A, 50 / 60 Hz
	Without separator (see note 2)	200 to 240 V, 7.0 A, 50 / 60 Hz
Heat Output	With separator (see note 1)	3,400 kJ / 810 kcal
	Without separator (see note 2)	3,310 kJ / 790 kcal

Motors	FFU-4055	420 W x 1 / 60W x 1
	RD-4055	400 W x 2
	SPC-4055	90 W x 1 / 15 W x 1
Machine Dimensions	With separator (see note 1)	W3,584 x D820 x H1,195 mm / W141.2" x D32.3" x H47.1"
	Without separator (see note 2)	W2,510 x D820 x 1,195 mm / W98.9" x D32.3" x H47.1"
Noise Level	LAeq: 73.7 dB	
Machine Weight	With separator (see note 1)	890 kg / 1,962.45 lb
	Without separator (see note 2)	770 kg / 1,697.85 lb
Recommended Air Source	With separator (see note 1) With Stacker (See note 3)	Rated Output of Prime Mover(Reference): 0.75 kW Maximum Operating Pressure: 0.8 MPa Minimum Required Pressure: 0.6 MPa or more Minimum Discharge: 85 Liters per minute Type: Oil-free Type
	Without separator (see note 2)	Rated Output of Prime Mover: 0.2 kW Maximum Operating Pressure: 0.8 MPa Minimum Required Pressure: 0.6 MPa or more Minimum Discharge: 20 Liters per minute Type: Oil-free Type
Temperature and Humidity	Temperature +0 to -40°C / 32 to 104°F, Humidity 20% to 80%RH (No condensation)	

The machine design and specifications are subject to change without notice.

With separator (note 1) : System configuration consists of FFU-4055 + RD-4055 + SPC-4055.

Without separator (note 2) : System configuration consists of FFU-4055 + RD-4055 + BT-4055.

With Stacker (note 3): System configuration consists of FFU-4055 + RD-4055 + ST-4055.

7-1-1 Closeup of Roller Gap and Die

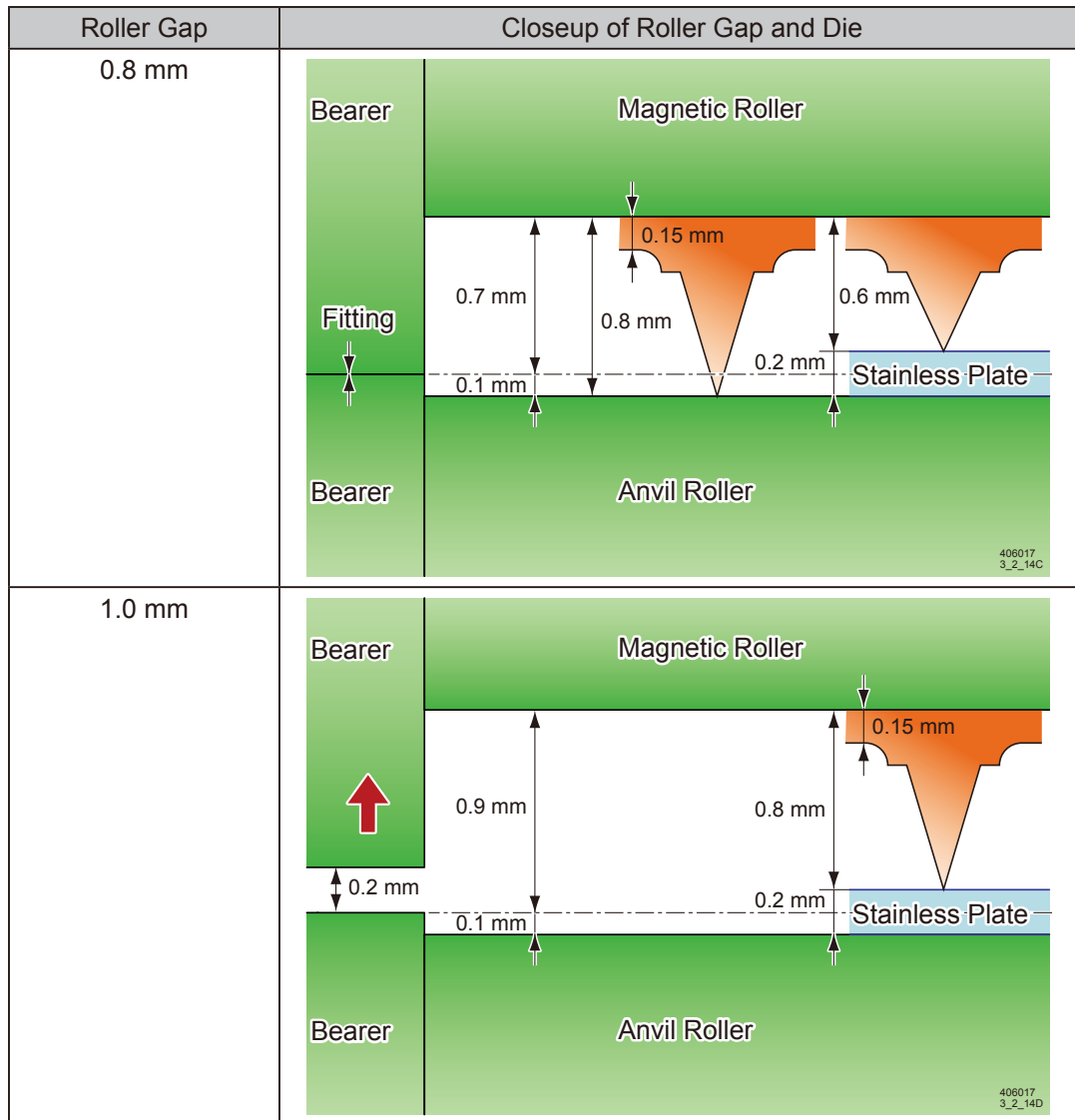

7-2 Accessories

7-2-1 Accessories for the RD-4055

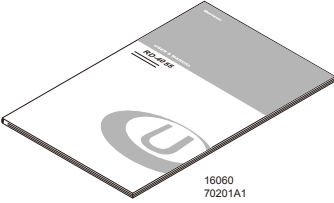
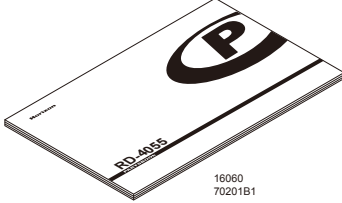
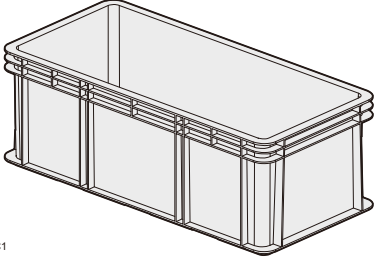
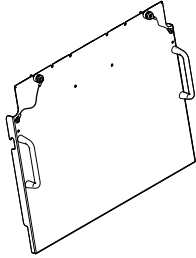
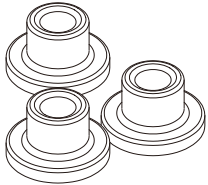
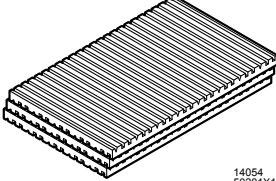
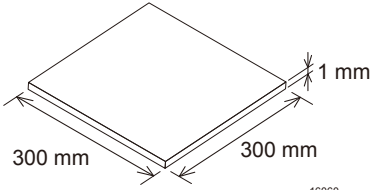
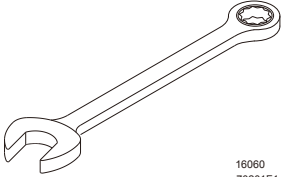
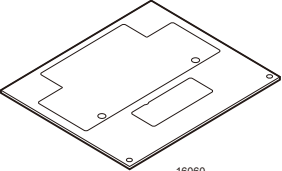
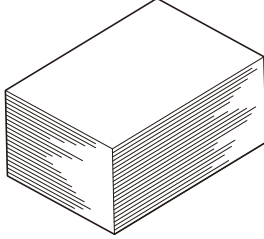
User's Manual	1 pc	 <p>16060 70201A1</p>	Parts Book	1 pc	 <p>16060 70201B1</p>
Green Container	1 pc	 <p>16060 70201C1</p>	Upper Die Attaching Tool	1 pc	 <p>This tool can be stored under the transport section of the SPC-4055.</p> <p>16060 70201E1</p>
Mounting Feet	3 pcs	 <p>16060 70201D1</p>	Rubber Cushions	3 pcs	 <p>14054 50201X1</p> <p>Put these cushions between the mounting plate and floor if necessary.</p>
Sponge Sheet	1 pc	 <p>16060 70201G1</p> <p>Attach this to the upper die to prevent the sheets from sticking to the die.</p>	Ratchet Wrench	1 pc	 <p>16060 70201F1</p>
Upper Die for Position Checking	1 pc	 <p>16060 70201Y1</p>	Cardboard	1 set	 <p>16060 70201Y2</p> <p>100 sheets, 270gsm, 235 X 318 mm</p> <p>Use these to test the die cutting using the die shown in the drawing to the left.</p>

Accessories

Urethane Tube (5 m / 196.9")	1 pc
------------------------------	------

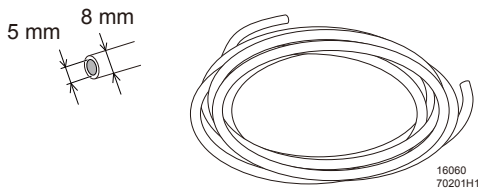

16060
70201H1

Use this to connect the RD-4055 to the compressor.

Straight Joint	1 pc
----------------	------

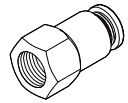

16060
70201Q1

This joint is unnecessary when the RD-4055 is connected to the SPC-4055.
(Store it in the tool box.)

Regulator and Mounting Plate	1 set
------------------------------	-------

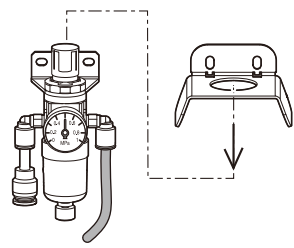

16060
70201X1

Digital Caliper	1 pc
-----------------	------

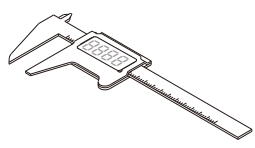

16060
70201I1

Tool Box	1 pc
----------	------

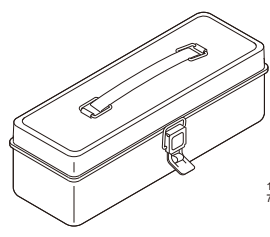

16060
70201J1

This box includes following tools.

Wrenches	1 pc each
----------	-----------

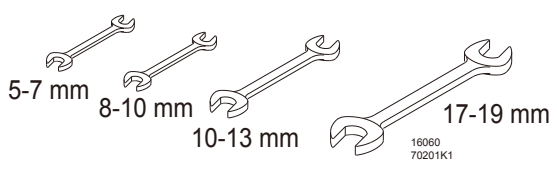

5-7 mm 8-10 mm 10-13 mm 17-19 mm

16060
70201K1

Single Open-End Wrench	1 pc
------------------------	------

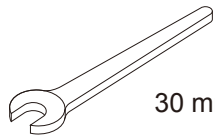

30 mm

16060
70201L1

Allen Wrenches	1 set
----------------	-------

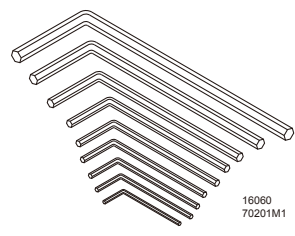

10 mm
8 mm
6 mm
5 mm
4 mm
3 mm
2.5 mm
2 mm
1.5 mm

16060
70201M1

Phillips Head Screwdriver	1 pc
---------------------------	------

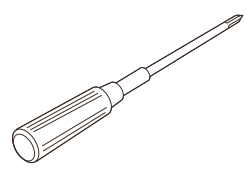

16060
70201N1

Hex Driver	1 pc
------------	------

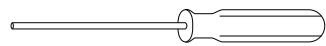

3 mm

14054
50202I1

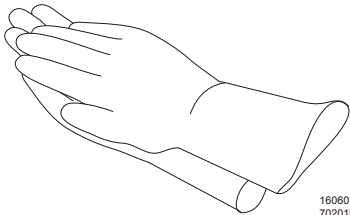
Gloves	1 pair
 <p>16060 70201P1</p>	

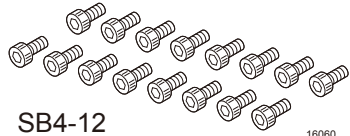
Locking Screws for Clamps on Lower Die (Spare)	16 pcs
 <p>SB4-12</p> <p>16060 70201W1</p>	

Grease Cup	1 pc
 <p>16060 70201R1</p>	

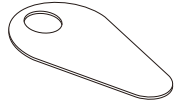
Die Removal Plate	1 pc
 <p>16060 70201S1</p>	

#220 Slide Oil	1 pc
 <p>16060 70201T1</p>	

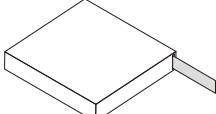
Cutting Blade Height Adjusting Strip	1 pc
 <p>16060 70201V2</p> <p>Stainless, thickness: 0.01 mm, Length: 1 m Attach this to the rear of the upper die to assist the cutting action.</p>	

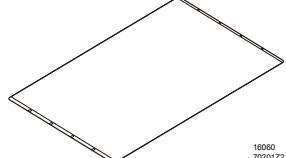
Large Stainless Sheet for Lower Die	1 pc
 <p>16060 70201Z2</p> <p>When the machine is shipped, this sheet is inside a box, and the box is attached to the machine. Install this sheet at the lower die when machine installation.</p>	

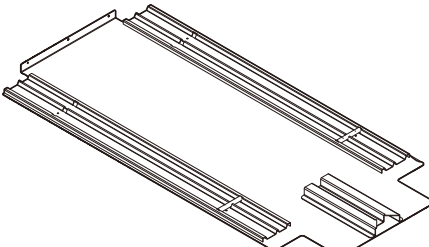
Rail Plate	1 pc
 <p>16060 70203A1</p>	

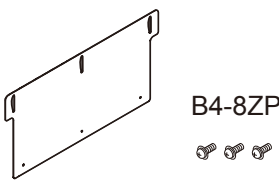
Docking plate for the rail plate	1 pc
 <p>B4-8ZP</p> <p>16060 70203A2</p>	

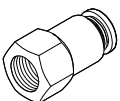
Straight Connector	1 pc
 <p>16060 70201Q2</p>	

Accessories

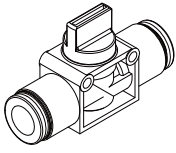
Hand Valve	1 pc
 16060 70201U1	

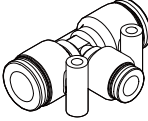
"T" Connector	1 pc
 16060 70201O1	

7-2-2 Accessories for the FFU-4055

Guide Rods	5 pcs
------------	-------

Not used

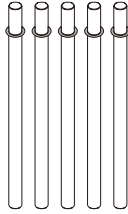

16060
70202A1

Double Feed Stop Plate Assembly	1 pc
---------------------------------	------

Not used

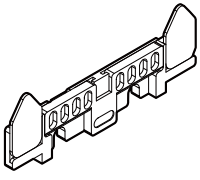

16060
70202B1

7-2-3 Accessories for the SPC-4055

Adhesive Tape	1 pc
---------------	------



16060
70401C1

Width: 40mm, Length: 80 cm

Trash Box	2 pcs
-----------	-------

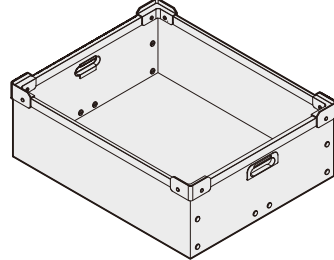

16060
70203E1

Support Plate	1 pc
---------------	------

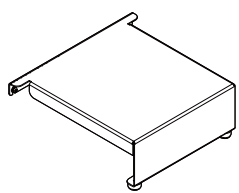

16060
70203B1

Scale (600 mm)	1 pc
----------------	------

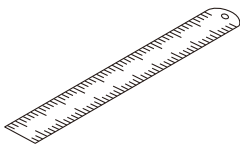

16060
70203C1

Urethane Tube (6 m / 0.19")	1 pc
-----------------------------	------

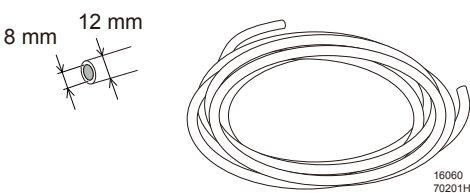

8 mm 12 mm

16060
70201H1

Use this to connect the SPC-4055 to the compressor.

7-2-4 Accessories for the BT-4055

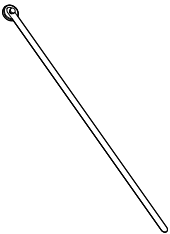
Guide Strip	1 pc
 <p style="text-align: right;">16060 70204A1</p>	

7-2-5 Accessories for the LDK-4055

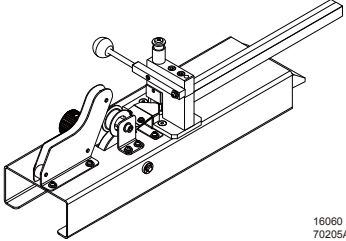
Tape Cutter	1 pc
 <p style="text-align: right;">16060 70205A1</p>	

10 mm Creasing Tape	1 pc
 <p style="text-align: right;">16060 70401C1</p> <p>Thickness: 0.3 mm, Width: 10 mm, Length: 20 m</p>	

25mm Creasing Tape	1 pc
 <p style="text-align: right;">16060 70205C1</p> <p>Thickness: 0.3 mm, Width: 25 mm, Length: 2 m</p> <p>Use this tape if two creasing lines are close together. You can make two grooves on one piece of this tape.</p>	

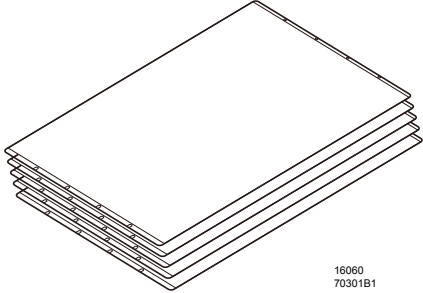
Large Stainless Sheets for Lower Die	5 pcs
 <p style="text-align: right;">16060 70301B1</p> <p>400 x 550 mm / 15.74" x 21.65"</p>	

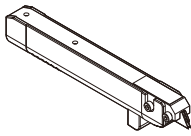
Cutter Holder	1 pc
 <p style="text-align: right;">16060 70205D1</p>	

L Plate	1 pc
 <p style="text-align: right;">16060 70205E1</p>	

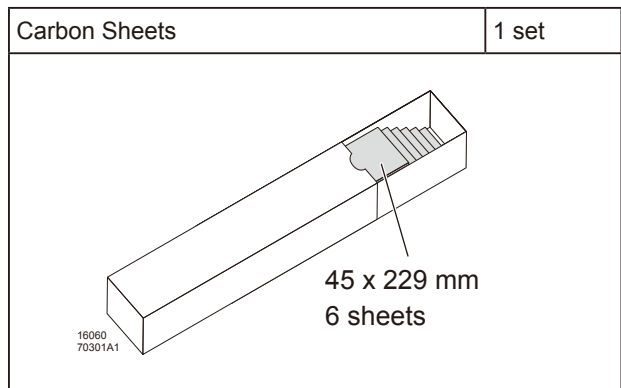
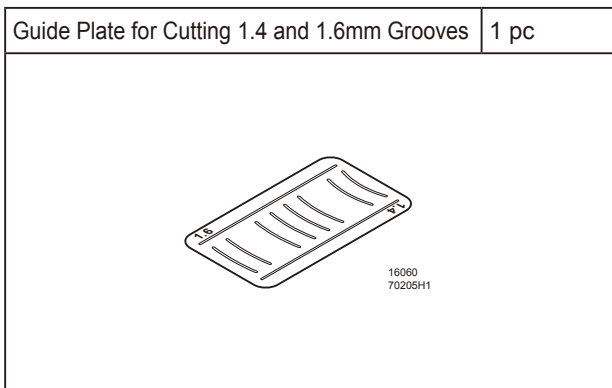
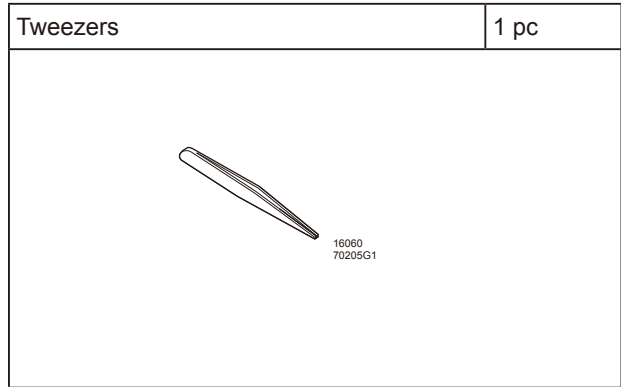
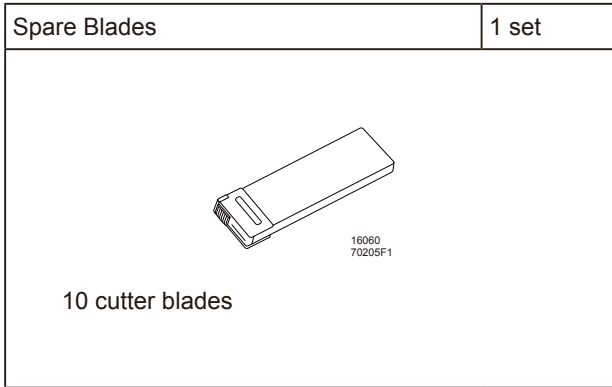

7-3 Consumables

The following materials are consumable. Order replacement materials as you use up the supplied ones.

10mm Creasing Tape	1 pc
 <p>16060 70401C1</p> <p>Thickness: 0.3 mm, Width: 10 mm, Length: 20 m</p> <p>Parts Book: Fig. 210 - Index 2</p>	

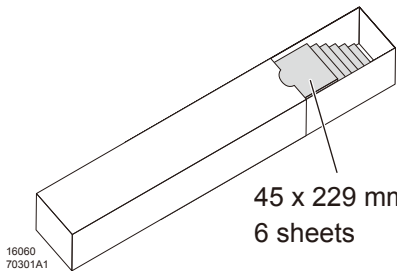
Carbon Sheets	1 set
 <p>16060 70301A1</p> <p>45 x 229 mm 6 sheets</p> <p>Parts Book: Fig. 210 - Index 9</p>	

The consumables above are used to create the lower die for creasing. (See page 84.)

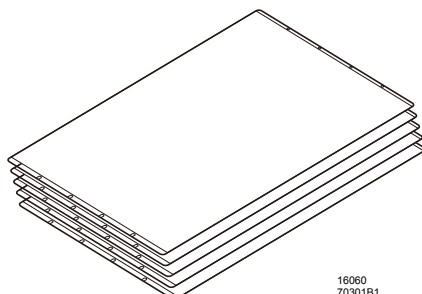
Large Stainless Sheets for Lower Die	5 pcs
 <p>16060 70301B1</p> <p>400 x 550 mm</p> <p>Parts Book: Fig. 210 - Index 1 One of these stainless sheets is shipped with the RD-4055.</p>	

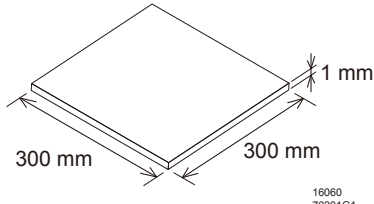
Sponge Sheet	1 pc
 <p>16060 70201G1</p> <p>Parts Book: Fig. 90 - Index 21</p> <p>Attach sections of this material on the upper die to prevent the sheet from sticking to the die.</p>	

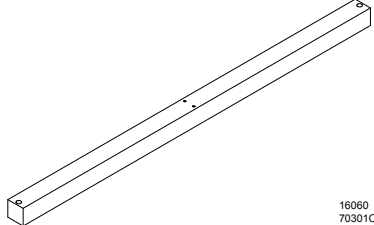
Guide Support Bar	1 pc
 <p>16060 70301C1</p> <p>Parts Book: Fig. 107 - Index 1</p> <p>This bar may be marked by the screws which are used to install this bar. Replace this bar if necessary.</p>	

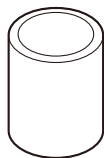
Filter of Filter Regulator (For SPC-4055)	
 <p>14054 50301D1</p> <p>Parts Book: Fig. 123 - Index 7</p>	

Filter of Filter Regulator (For RD-4055)	
 <p>1606 70301A1</p> <p>Parts Book: Fig. 70 - Index 19</p>	

7-4 Optional Parts

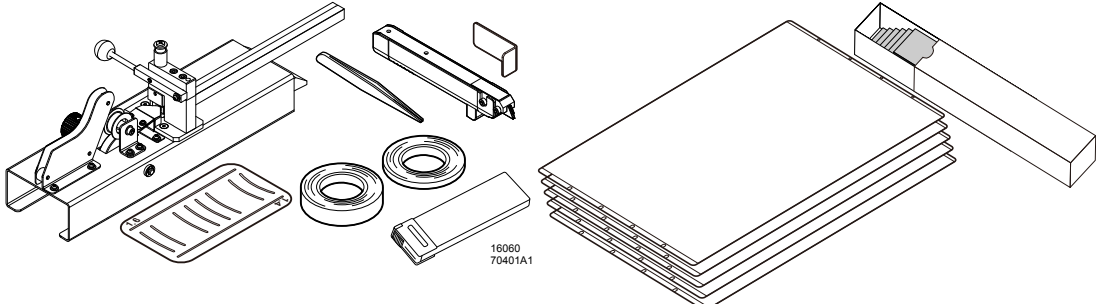
Lower Die Tool Kit LDK-4055	1 set
	

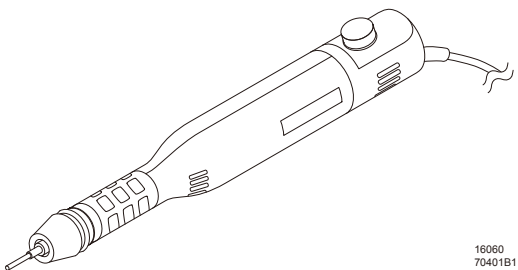
Hand Router for Creating Nicks	1 pc
	

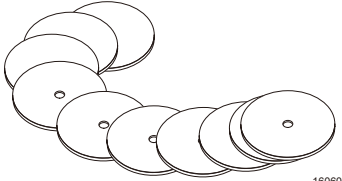
Router Cutters	10 pcs
 <p style="text-align: center;">Diameter: 22 mm Thickness: 0.25 mm</p>	

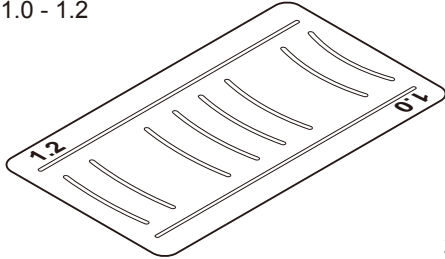
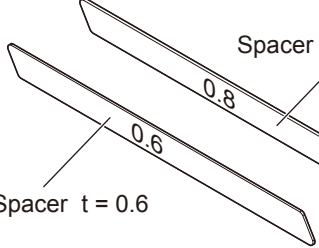
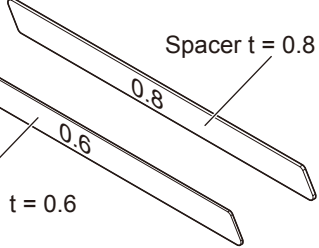
Guide Plate for Cutting Grooves Kit	1 set
<p>Guide Plate for Cutting Grooves 1.0 - 1.2</p>  <div style="display: flex; justify-content: space-around; align-items: center; margin-top: 20px;"> <div style="text-align: center;">  <p>Spacer t = 0.6</p> </div> <div style="text-align: center;">  <p>Spacer t = 0.8</p> </div> </div>	

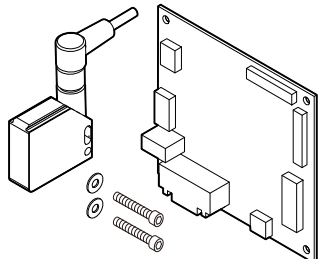
Mark Sensor MS-3346	1 set
 <p style="margin-left: 20px;">LCD Power Board (QPW-942) Parts Book: Fig. 93 - Index 3</p>	

10mm Creasing Tape	1 pc
 <p style="margin-left: 20px;">Thickness: 0.3 mm, Width: 10 mm, Length: 20 m</p>	

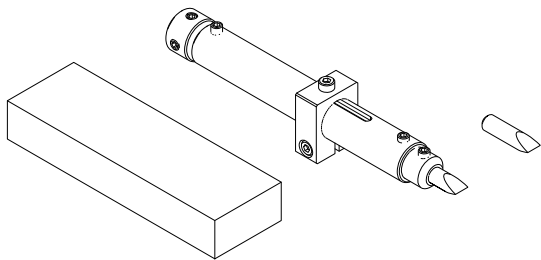
Nick Punch	1 set
	

6-1 Safety Precautions

⚠ WARNING



- The weights for each unit are as follows: The FFU-4055 weighs 140 kg (308.7lb), the RD-4055 weighs 580 kg (1278.7lb), the SPC-4055 weighs 170 kg (374.8lb), and the BT-4055 weighs 45 kg (99.3lb).
- When moving these machines, use a transport method which is appropriate to the weight.
- When installing the machines, use a torpedo level to check that the floor is flat and level.
- Do not make the final connection to the power distribution board until all of the other wiring connections are completed. Otherwise an electric shock could cause severe personal injury.

Installation Space

System Including SPC-4055 Separator

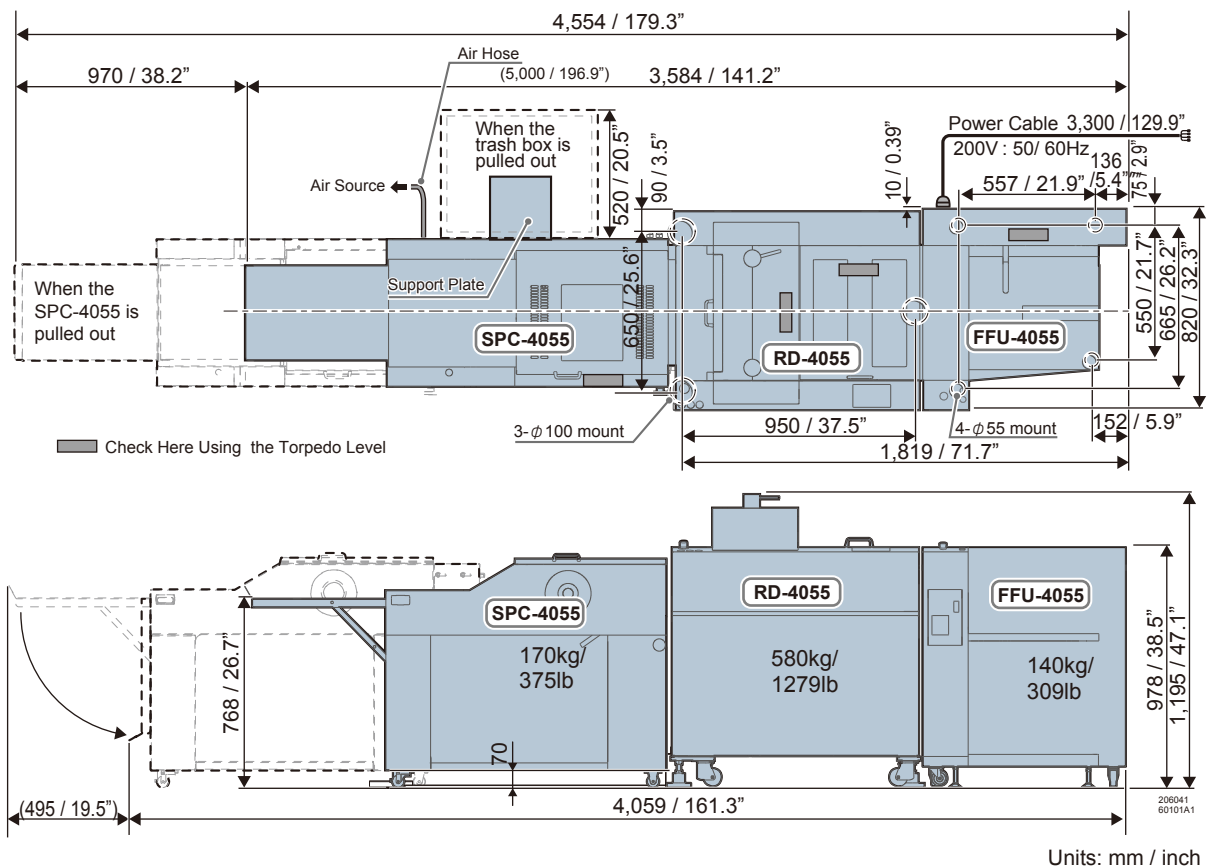

Compressor Specifications

Use a compressor with the following specifications:

Rated Output of Prime Mover (Reference):	0.75 kW
Maximum Operating Pressure	0.8 MPa
Minimum Required Pressure	0.6 MPa or more
Minimum Discharge	85 Liters per minute
Type	Oil-free Type

System Including BT-4055 Bucket Receiving Tray

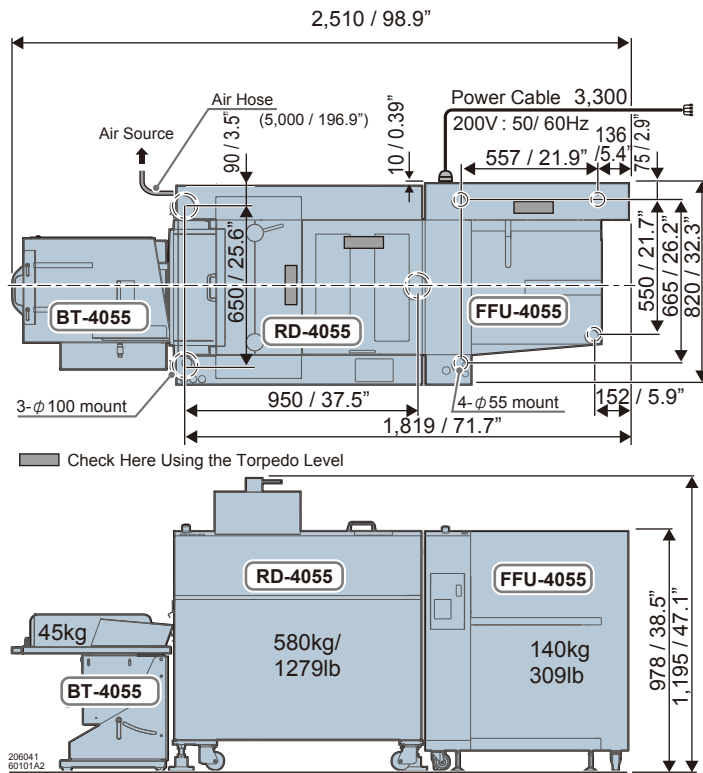

Compressor Specifications

Use a compressor with the following specifications:

Rated Output of Prime Mover (Reference)	0.2 kW
Maximum Operating Pressure	0.8 MPa
Minimum Required Pressure	0.6 MPa or more
Minimum Discharge	20 Liters per minute
Type	Oil-free Type

Units: mm / inch

Sizes and Weights of Individual Units

BT-4055 Bucket Receiving Tray (Optional)
Weight : 45 kg (99.3lb)

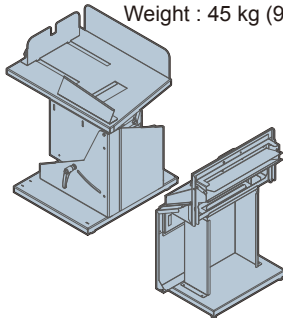

RD-4055 Rotary Die Cutter
Weight : 580 kg (1278.7lb)

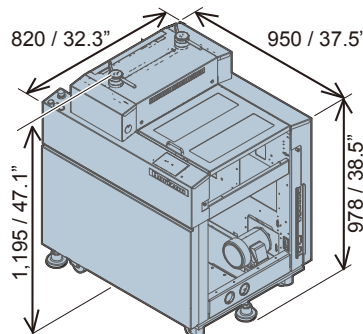

FFU-4055 Sheet Feeder
Weight : 140 kg (308.7lb)

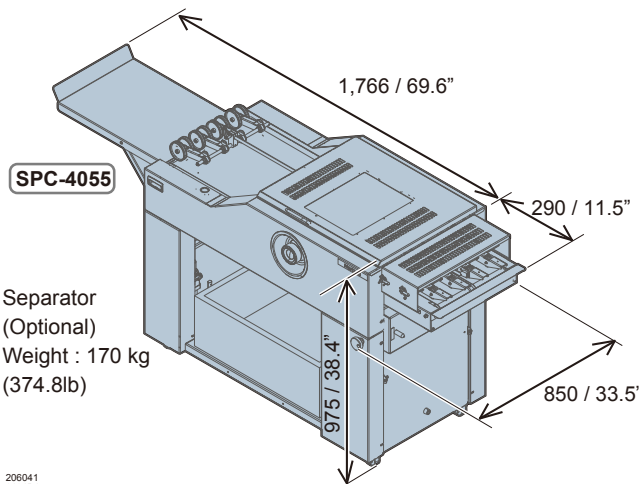
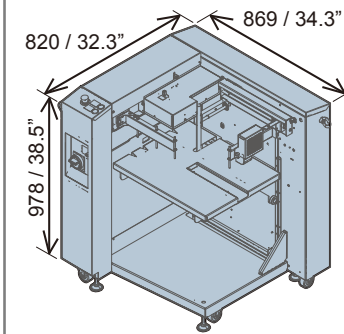

Additional Information

The rotary die cutter RD-4055 has lifting holes in its frame.

