

Digital Die Cutter for 13 inch x 19 inch sheets



CCD Registration System



LCD Control System



Sheet Separator

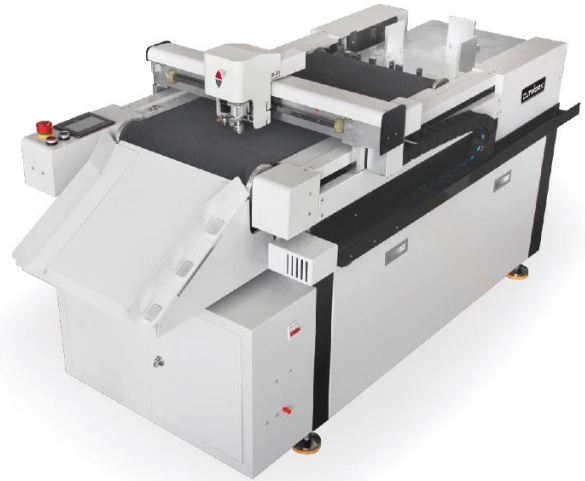
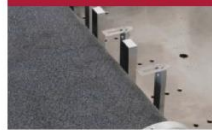

Cost effective Digital Cutting System

The LST 1319 is the perfect cost effective solution for a variety of finishing requirements for adhesive sheets, business cards, specially shaped cards, invitations, labels, small packaging, tags and more. Increase your productivity and profitability by having an in house multi function digital cutting solution designed for short run on demand production. You can cut, kiss cut, die cut and crease a variety of paper and card stock up to 18 pt and sheet sizes up to 13 x 19 inches.

Accuracy and Speed

The LST 1319 included a high resolution CCD vision camera system designed to read crop marks on the media to the original value of the digital file for precision cutting accuracy of 0.08 inch/0.2 mm. The LST can cut and crease a folding carton up to 18 pt in 30-60 seconds, depending on the complexity of the carton design.

No Cutting Dies

The LST 1319 is integrated with a cutting tool, creasing wheel tool and plotting pen. Simple export your Adobe Illustrator or CorelDRAW files in a DXF, PLT, or HP/GL to the LST controller for processing and cutting requiring no physical dies saving you money and time.

Automatic Sheet Fed Production

The automatic sheet feeding and cutting system is designed to load and cut without the need of an operator.

Features

- ▶ All in one pass Up to 3 tools (including creasing wheel) on 3 head units
- ▶ CCD Camera registration for accurate sheet alignment
- ▶ Easy to use file management software
- ▶ Automatically sketch contours of design file and Track cutting time
- ▶ Precision cutting accuracy of 0.08 inch/0.2 mm
- ▶ Repeat accuracy of 0.047 inch 0.1 mm
- ▶ Add additional sheets to the feeder without resending the job
- ▶ Capable of handling up to 200 sheets of media in a continuous cycle
- ▶ QR code scanning (extra barcode scanner required)

Combine the LST with the Matrix Laminator foil fusion machine to create high end cards, brochures and packaging with foil or soft touch lamination.

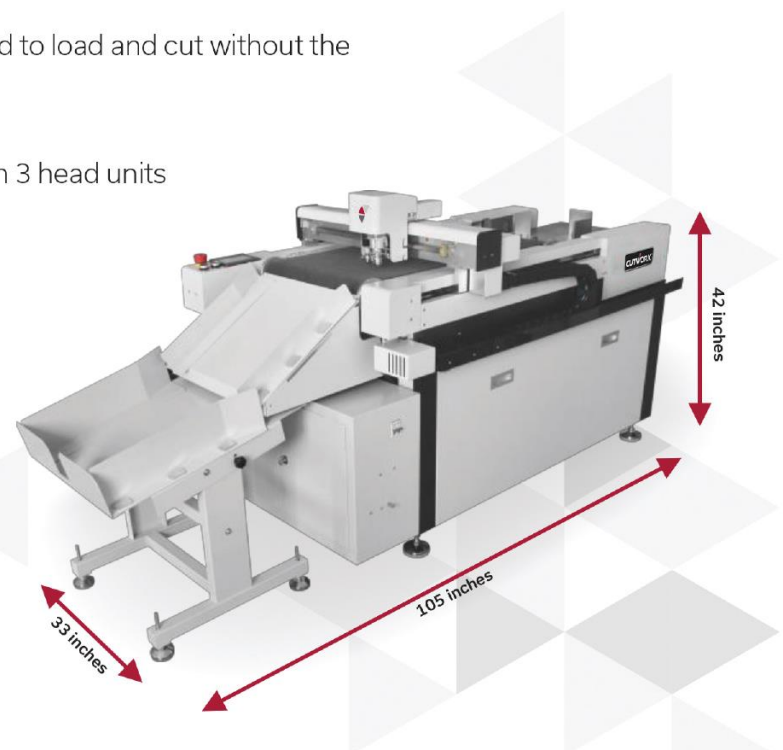

LST 1319

Digital Die Cutting System

WORKFLOW



Digital printing prototyping & short-run production

Laminating & Foiling

Finishing

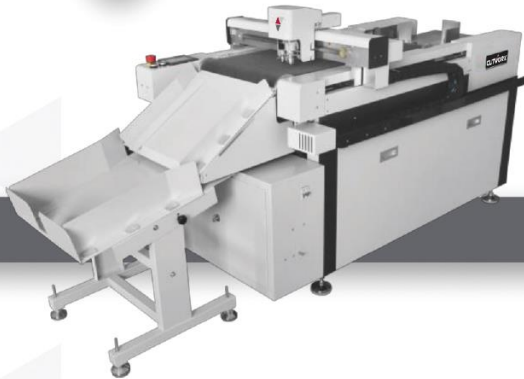

Cards



Labels



Packaging

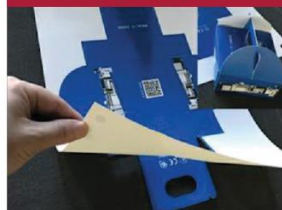

Packaging



Packaging



LST 1319 Specifications

Material	Art paper, card stock, labels and stickers
Effective work area	23 ½ x 15 ½ inch (600 x 400 mm)
Maximum cutting speed	31 inch/min (800 mm/min)
Effective cutting width	15 ½ inch (400 mm)
Cutting capacity	Up to 0.06 inch (1.5mm)
Cutting Accuracy	0.08 inch (0.2 mm)
Repeat accuracy	0.047 inch (0.1 mm)
Tools mountable	Up to 3 (including creasing wheel) on 3 head units
Display	Touch screen
Interface	Ethernet
Voltage	220 V single phase
Vacuum pump power	1.5 kW
Work surface	Felt mat