

# Horizon

STITCHING

# ICE STITCHLINER Mark IV

Next Generation  
Saddle-Stitching system

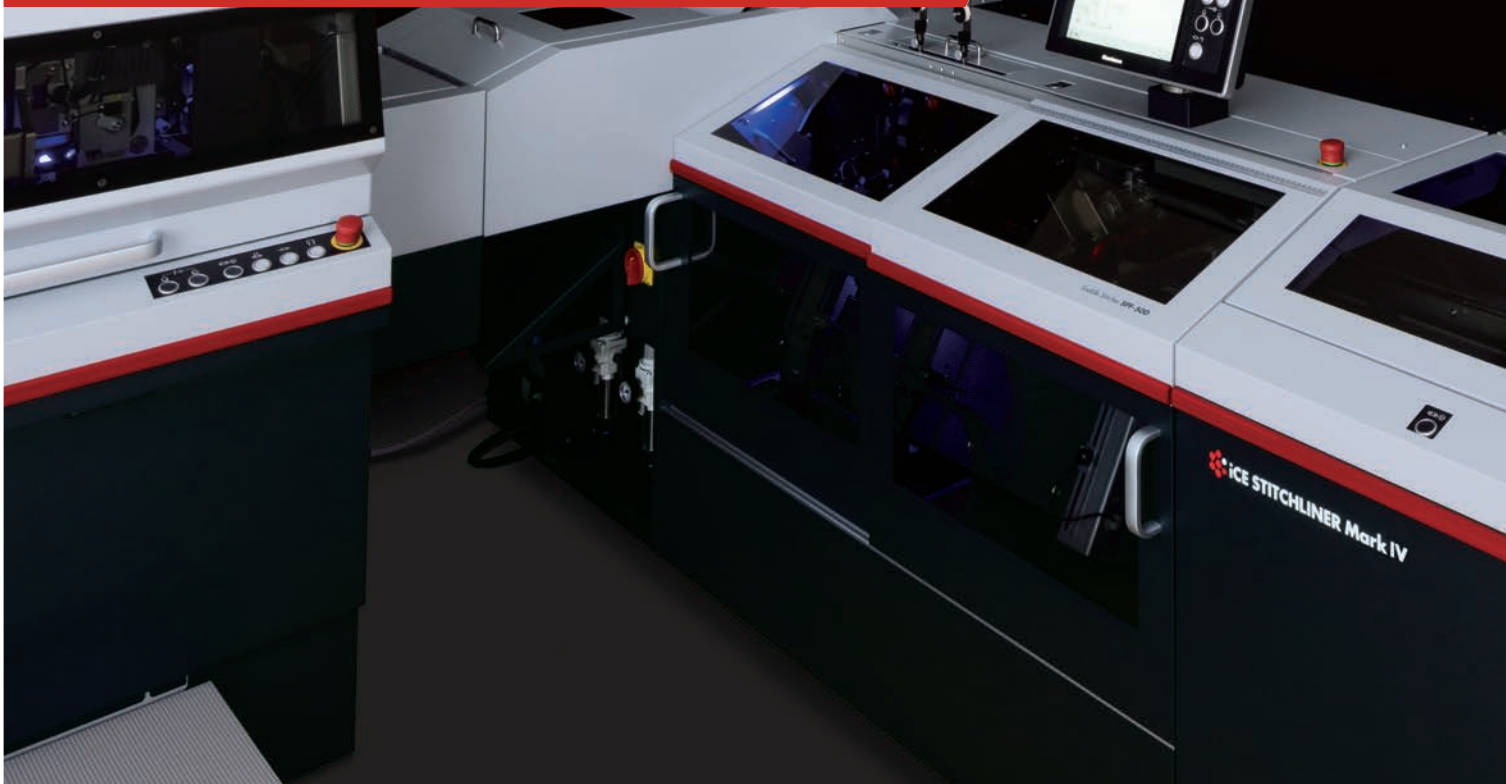

 **iCE Series**

**i** = Intelligence, Integration, Interaction  
**C** = Connection  
**E** = Efficiency

**All Connected...**

**Optimize the finishing process with automation and workflow.**

The iCE series is a new product line-up which is designed to provide added value to our customers. A new operator interface for a more intuitive operation, and advanced automation to provide increased efficiency and productivity. In addition, connecting with an iCE LiNK workflow system provides an advanced and totally connected work environment.

## **THE STITCHLINER CONCEPT.**

Combining the efficiency and ease of operation of flat sheet collating with the productivity, versatility and quality of a saddle-stitching system.

### **BENEFITS**

#### **FULLY-AUTOMATED SETTINGS**

All necessary settings for a wide variety of booklet formats can be performed automatically according to the booklet format and thickness. Advanced automation brings consistent high quality production with efficiency and high productivity.

#### **HIGH QUALITY**

Professional quality production is achieved with our unique systems for sheet transport and jogging, scoring and folding, stitch and fold monitoring, and positive jog register at the trimmer.

#### **VARIABLE THICKNESS PRODUCTION**

True end to end automation for variable thickness production. Variable stitch length and balance adjustment combined with variable thickness transport adjustment through the trimmer.

#### **WIDE VARIETY OF BOOKLET FORMATS**

The system can produce a wide range of applications, including A4 landscape booklets for large format calendar production, and pocket booklets. Higher productivity is achieved on A4 portrait at 6,000 booklets per hour and A4 landscape at over 5,000 booklets per hour.

#### **FLEXIBLE SYSTEM CONFIGURATION**

The iCE STITCHLINER Mark IV can be integrated with the VAC series collator and HOF-400 high-speed sheet feeder. The feeding system and other optional devices can be configured depending on your needs including for offset or digital print output.

#### **MANAGE YOUR BINDERY WITH HORIZON'S BINDERY CONTROL SYSTEM**

The iCE Series can be enhanced with automated workflow from upstream to postpress with iCE LiNK, which uses cloud technology, Horizon's next generation bindery control system.

# DETAILED PROCESS.

Advanced features for high quality and efficient production.

## ACF-50 Accumulator and Folder

Uniquely designed accumulating and folding section achieves high quality and high speed production with a wider range of substrates and formats.

## SPF-50 Saddle-Stitcher

Sets are jogged, stitched and transported to the three knife trimmer. Stitch length and balance are adjusted automatically according to thickness information.

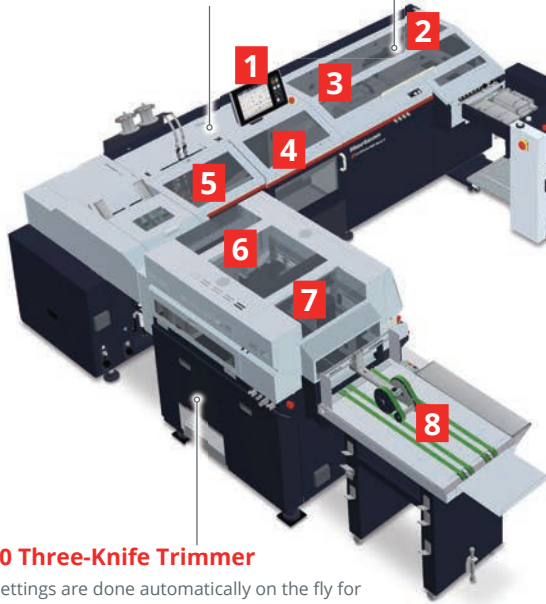

## HTS-50 Three-Knife Trimmer

All the settings are done automatically on the fly for variable thickness production. Uniquely designed four-side jogging achieves accurate trimming quality with 1-up or 2-up production.

## ST-40 or BC-20 Bypass Stacker

Serves as a bypass and error reject station for continuous booklet production. Straight or offset stacking can be achieved across a wide range of substrates.

## VAC-1000 / L1000 / 600H / L600H Collator

Conventional flat sheet collator which is used for collation of offset printed work.

## HIF-400 Hybrid Conveyor

The HIF-400 connects the HOF-400 (AC-400) high-speed sheet feeder with the collator to process both digital and offset print in one system.

## BVS-400 Barcode Verification System

The BVS-400 verifies page order to prevent missing pages or the wrong order in booklets. (\*The CV-400 conveyor is necessary to mount the barcode reader.)

## AC-400 Accumulator

The AC-400 accumulates the sheets from the HOF-400 for higher productivity and auto-reject of errored sets.

## HOF-400 High-speed Sheet Feeder

The HOF-400 feeds digitally printed sheets. Capable of feeding variable sheet count with standard mark reading. The CF-400 cover feeder is available as an option.

\*The picture above shows an example of a configuration with the VAC series and HOF-400. The system can also be configured with only the VAC series or HOF-400.

## 1 TOUCH PANEL DISPLAY

The 12.1 inch color touch-screen is icon-based for user-friendly operation. Each finishing station is automatically set by simply inputting the sheet size and booklet size on the touchscreen. Up to 999 job settings can be stored in job memory for quick and easy recall.



## 3 SCORING SECTION

Scoring function to reduce cracking on the spine and tighter folding quality. Adjustable gap and scoring pressure to apply suitable scoring quality depending on substrate.

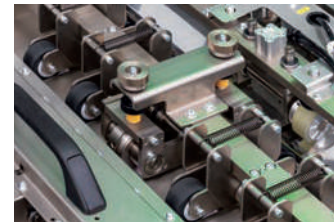

## 2 JOG SECTION

Uniquely designed transport and jogging mechanism achieves high speed and stable production with a wider range of substrates and formats.



## 4 FOLD SECTION

Folding function for high quality fold for a wide range of substrates and formats. Improved folding mechanism for sharper and tighter folding quality with improved accuracy.

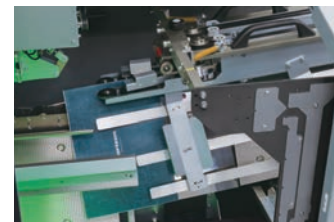

## SHEET FLOW

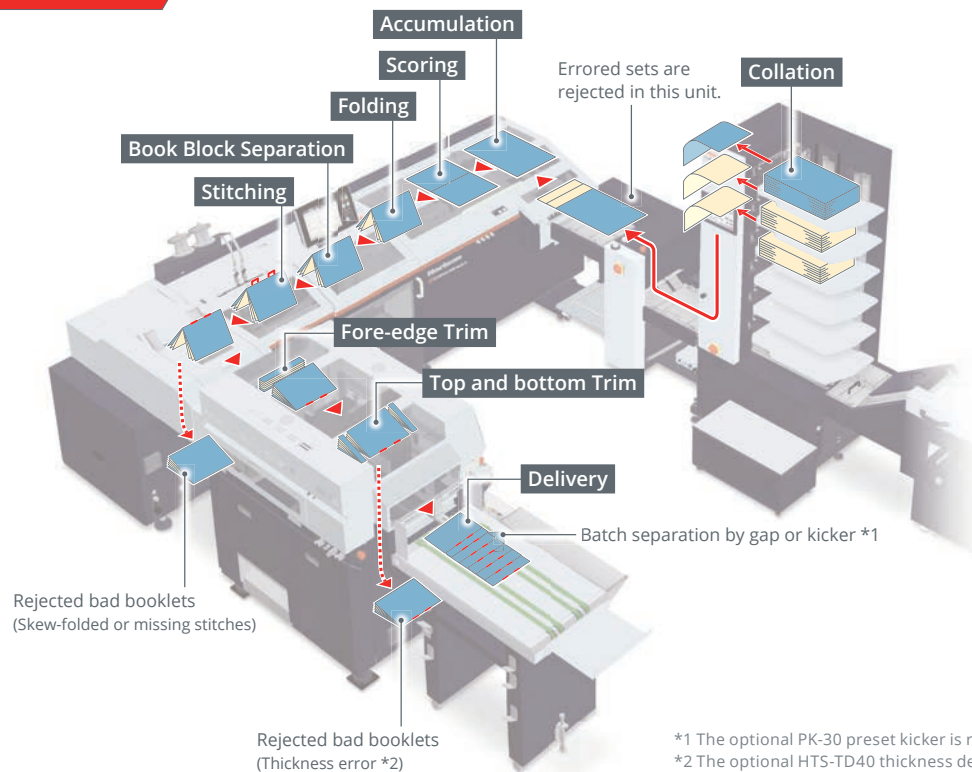

\*1 The optional PK-30 preset kicker is required.

\*2 The optional HTS-TD40 thickness detector is required.

### 5 STITCHING SECTION

Booklets up to 10 mm thickness\* can be stitched. Stitch position, stitch length, stitch balance, and stitch detection sensor position are all automated. Various stitching options, including loop stitching, four stitch heads and center stitch heads are available. Optional wire drive device WDD-SPF50 automatically adjusts stitch length according to the booklet thickness for variable thickness production with higher accuracy.

\*About 50 sheets of Normal Paper 81.4 gsm

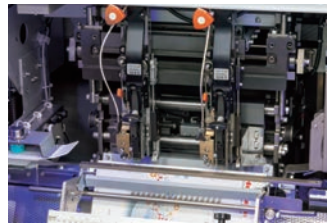

### 7 TOP AND BOTTOM TRIM SECTION

The booklet is jogged on four sides for accurate and consistent trimming quality. Uniquely designed air assisted trim removal to drop the trim waste efficiently. Optional center-cut knives are available for 2 up production.

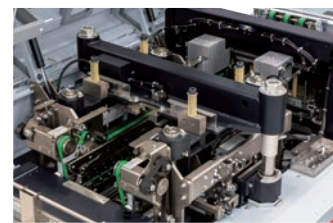

### 6 INFED SECTION / FORE-EDGE TRIM SECTION

The servo-motor controlled transport system provides smooth booklet transport at high speeds even with lighter substrates and thinner booklets. The registration guides and trim size are automatically adjusted according to the sheet size and thickness.

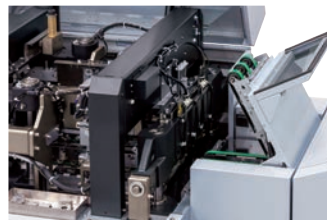

### 8 DELIVERY SECTION

Finished booklets are consistently delivered to the exit conveyor. Automated positioning of delivery roller and the expanded conveyor are available as an option. The optional PK-30 preset kicker separates a batch of booklets at a predetermined count.



# FEEDING OPTIONS.

High Performance Feeding Options.

## COLLATORS

### VAC-1000 / VAC-600H / VAC-L1000 / VAC-L600H

High speed and stable collation for a wide variety of paper stocks. Advanced programming functions for easy and efficient collating.

#### STABLE FEEDING

Unique rotary suction feeding system provides stable sheet feeding for a wide variety of paper stocks even folded signatures.

#### HIGH QUALITY

The block feed feature separates one book block into several sections to enhance the folding quality for thick booklet production. Reducing the number of sheets processed at one time in the fold section on the Stitching system provides sharper and tighter folding quality.

#### NON-STOP PRODUCTION

The double cycle feature can divide bins/towers into two sections and switch between them automatically for continuous operation with minimized downtime for sheet loading.

#### RELIABLE PRODUCTION

The reliable double feed detection insures the reject of errored sets. Optional image checker (IC2-V600) is available as an option to ensure page order and integrity for higher quality control.

### VAC-L1000 / VAC-L600H

Expanded paper size capacity to produce A4 landscape booklets efficiently.

\*Additional features on the VAC-L1000/L600H

#### EXPANDED PAPER SIZE CAPACITY

Sheets up to 610 mm (24") in length can be loaded for A4 landscape booklet production. An optional extra side blower can be equipped for stable feeding of large size or heavier weight substrates.



#### TOWER SELECTION

##### VAC-1000 / VAC-L1000 for multiple page jobs

10 bins in a single tower. Up to 6 towers can be connected for a 60-bin system.



VAC-1000  
(20 bins)



VAC-L1000  
(30 bins)

##### VAC-600H / VAC-L600H for longer run production

6 bins in a single tower. Up to 6 towers can be connected for 36-bin system. Each bin has 130 mm or 5.11" pile height capacity. The IC2-V600 image checker is available as an option.



VAC-600H  
(12 bins)



VAC-L600H  
(12 bins)

#### IMPROVED FEEDING PERFORMANCE

Individual air supply at each bin provides independent adjustment depending on paper stock and quality for stable and efficient feeding.

#### DIGITAL FEEDING

The D-VAC600 digital feed kit is provided as standard equipment to allow the collator to run as a feeder for digital prints. The system can be easily switched from the collator and feeder on the touch panel.

# HIGH-SPEED SHEET FEEDER

## HOF-400

Near-Line Solution for cut sheet digital printing.

### HIGH SPEED FEEDING

Digitally collated sheets are reliably fed into the saddle-stitching system at a maximum speed of 25,000 sheets per hour with A3 or 11" x 17" and 35,000 sheets per hour with A4 SEF or 8.5" x 11". This high speed feeding is capable of handling the output of multiple printers.

### VARIABLE THICKNESS PRODUCTION

A standard mark sensor enables variable sheet count documents to be handled with integrity and verification. The VAC series collator can be connected in-line, for processing of conventional offset printed work.

### USER FRIENDLY OPERATION

Features 7" color touch screen display for easy and intuitive operation. The HOF-400 is equipped with a high quality feed detection system for reliable processing. If mis-feeding occurs in the HOF-400, the errored set is ejected before stitching.

### SPECIFICATIONS.

	VAC-1000	VAC-600H
<b>Number of Bins</b>	10 bins (Max. 6 towers, 60bins)	6 bins (Max. 6 towers, 36 bins)
<b>Stack Capacity</b>	Height: Max. 55 mm or 2.16" Weight: Max. 11 kg or 24.3 lb each bin	Height: Max. 130 mm or 5.11" Weight: Max. 26 kg or 57.3 lb each bin
<b>Sheet Size</b>	<b>Width x Length</b> Max. 350 x 500 mm or 13.77" x 19.68" Min. 120 (*1) x 148 mm or 5.83" (*1) x 5.83" *1 Use the side guide for small sheets when handling sheets smaller than 148 mm or 5.83" in width. *2 Sheet size depends on the connected StitchLiner's specifications.	
<b>Machine Dimensions</b>	W 862 (a) 930 (m) 945 (c) x D 652 (*1) x H 1,962 mm or W 34.0" (a) 36.7" (m) 37.3" (c) x D 25.7" (*1) x H 77.3" W 862 (a) 930 (m) 945 (c) x D 652 (*1) x H 1,962 (*2) mm or W 34.0" (a) 36.7" (m) 37.3" (c) x D 25.7" (*1) x H 77.3" *1 Blower box excluded, 693 mm or 27.3" when including the projection *2 2,040 mm or 80.4" when including the IC2-V600 Pitch between towers: 810 mm or 31.9" Blower box: W 665 x D 345 x H 320 mm or W 26.2" x D 13.6" x H 12.6"	
	VAC-L1000	VAC-L600H
<b>Number of Bins</b>	10 bins (Max. 6 towers, 60bins)	6 bins (Max. 6 towers, 36 bins)
<b>Stack Capacity</b>	Height: Max. 55 mm or 2.16" Weight: Max. 11 kg or 24.3 lb each bin	Height: Max. 130 mm or 5.11" Weight: Max. 26 kg or 57.3 lb each bin
<b>Sheet Size</b>	<b>Width x Length</b> Max. 350 x 610 mm or 13.77" x 24.01" Min. 120 (*1) x 148 mm or 5.83" (*1) x 5.83" *1 Use the side guide for small sheets when handling sheets smaller than 148 mm or 5.83" in width. *2 Sheet size depends on the connected StitchLiner's specifications.	
<b>Machine Dimensions</b>	W 1,034(a) 1,100(m) 1,113(c) x D 686 (*1) x H 1,962 mm or W 40.7 (a) 43.3 (m) 43.8 (c) x D 27.1 x H 77.3" W 1,034 (a) 1,100 (m) 1,113 (c) x D 686 (*1) x H 1,962 mm or W 40.7 (a) 43.3 (m) 43.8 (c) x D 27.1 x H 77.3" *1 Blower box excluded, 726 mm or 28.6" when including the projection *2 2,040 mm or 80.4" when including the IC2-V600 Pitch between towers: 980 mm or 38.6" Blower box: W 665 x D 345 x H 320 mm or W 26.2" x D 13.6" x H 12.6"	



### A WIDE VARIETY OF OPTIONS

The HOF-400 is compatible with a wide variety of system configurations such as cover feeding, accumulating and barcode verification depending on your needs.

HOF-400	
<b>Sheet Size</b>	<b>Width x Length</b> Max. 356 x 610 mm or 14.0" x 24.0" Min. 203 x 203 mm or 8.0" x 8.0" 
<b>Sheet Weight Range</b>	Normal Paper: 52 to 157 gsm Coated Paper: 73 to 157 gsm *When you use thin sheets, you need to decrease the speed depending on the sheet size. *The machine can feed thick sheets or 157 through 209 gsm, but the feed speed will decrease.
<b>Sheet Pile Height on Feed Tray</b>	Max. 620 mm or 24.4"
<b>Production Speed</b>	Max. 25,000 sheets per hour (A3) 35,000 sheets per hour (A4 SEF) 45,000 sheets per hour (A4 LEF) *When the sheets are processed one by one. 4,000 booklets per hour (Without Creasing, 16-page, A4 size booklet) 3,200 booklets per hour (With Creasing, 16-page, A4 size booklet) 5,000 booklets per hour (Without Creasing, 16-page, A5 size booklet) 4,000 booklets per hour (With Creasing, 16-page, A5 size booklet) *The production speed is limited depending on the stitcher.
<b>Voltage/Frequency</b>	3-phase 200 to 220 V, 50 Hz or 60 Hz 3-phase 380 / 400 / 415 V, 50 Hz or 60 Hz
<b>Machine Dimensions</b>	W 960 x D 740 (*) x H 936 mm or W 37.8" x D 29.2" (*) x H 36.9" *D 1,050 mm or 41.4" when including the blower box Blower Box: W 553 x D 305 x H 350 mm or W 21.8" x D 12.0" x H 13.8"

# ADDITIONAL OPTIONS.

## Options for the VAC Series Collator.

### BC-20 BYPASS CONVEYOR / ST-40 BYPASS STACKER

#### FOR BOOKLET PRODUCTION

- The BC-20 or ST-40 transports collated sets from the VAC series to the saddle-stitching system.
- Errored sets are delivered to the built-in reject tray for non-stop operation.
- Hand feeding function is equipped for efficient small-lot production.
- The BC-20 or ST-40 easily switches over from bookletmaking to stacking. (\*The BC-20 requires the SW-20 receiving tray for stacking.)
- Sheet jam detection is provided for both bypass units. The LED lights show the location of jams on the BC-20 and the error code is shown on the control panel of the ST-40 for quick and easy recovery.

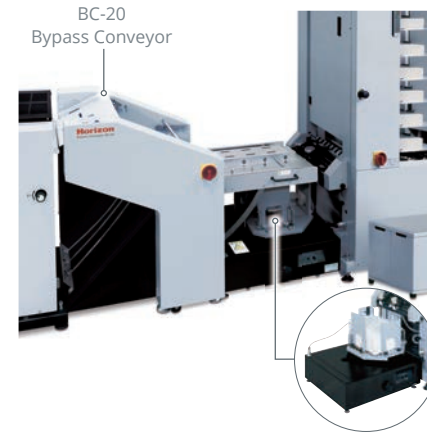

SW-20  
Criss-cross Receiving Tray

#### FOR COLLATING OPERATION

#### SW-20 CRISS-CROSS RECEIVING TRAY \*Connected to the BC-20

- Offset stacking mode to shift each collated set by 90 degrees in the tray.
- Stack capacity: Max. 170 mm / 6.7" (A5-A4)

#### ST-40 BYPASS STACKER

- Collated sets are jogged and stacked on the pallet.
- Offset stacking feature shifts each collated set laterally.
- Stack capacity: Max. 360 mm or 14.1"
- Counter feature enables stopping at the preset number of stacks automatically.



## SPECIFICATIONS.

BC-20	
<b>Sheet Size</b> 	<b>Width x Length</b> Max. 350 x 500 mm or 13.78" x 19.69" Min. 120 x 148 mm or 4.73" x 5.83"
<b>Sheet Weight Range</b>	Depends on the connected collator specifications.
<b>Production Speed</b>	Speed is set in three steps to match the driving speed of collator.
<b>Stack Capacity</b>	Max. 30 mm or 1.2"
<b>Voltage/Frequency</b>	Single Phase 200 to 240 V, 50 / 60 Hz
<b>Machine Dimensions</b>	W 1,255 x D 686 x H 910 mm or W 49.4" x D 27.0" x H 35.9"
SW-20	
<b>Sheet Size</b> 	<b>Width x Length</b> Max. 320 x 470 mm or 12.60" x 18.51" Min. 148x 210 mm or 5.83" x 8.27"
<b>Stack Pile Height</b>	Small Sheet Receiving Plate (A5-A4) 170 mm or 6.7" Large Sheet Receiving Plate (A4-A3) 100 mm or 4.0"
<b>Sheet Weight Range</b>	Depends on the connected collator specifications
<b>Machine Dimensions</b>	W 645 x D 560 x H 480 mm or W 25.4" x D 22.1" x H 18.9"

ST-40	
<b>Sheet Size</b> 	<b>Width x Length</b> Max. 350 x 500 mm or 13.8" x 19.7" (*) Min. 182 x 128 mm or 7.2" x 5.0" *Maximum 610 mm or 24.02" length of a sheet can be received on the stack tray by attaching the optional guide ST-LG on the stack tray.
<b>Sheet Weight Range</b>	52 to 208 gsm
<b>Stack Capacity</b>	360 mm or 14.1"
<b>Production Speed</b>	8,000 sets per hour (A4 or 8.5"x11", 10 sheets/straight stacked) 5,000 sets per hour (A4 or 8.5"x11", 10 sheets/offset stacked)
<b>Voltage/Frequency</b>	Single Phase 200 to 240 V, 50 or 60 Hz
<b>Machine Dimensions</b>	W 1,353 x D 652 x H 1,027 mm or W 53.3"x D 25.7" x H 40.5" (including feed error tray)

# ADDITIONAL OPTIONS.

## Performance Enhancing Options.

### SL6PS-40 SIX-PAGE COVER KIT

- Software to mix different length sheets such as 6-page signatures in a booklet.



- Different size sheets can be inserted in any position in a booklet.

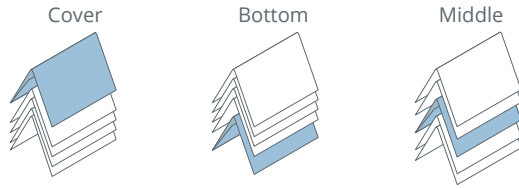

#### WHEN FEEDING FROM VAC SERIES

- Different size sheets can be inserted up to four positions in a booklet: front, back, and two other inserts.

\*Only one different size can be inserted for three or more positions.

Example:

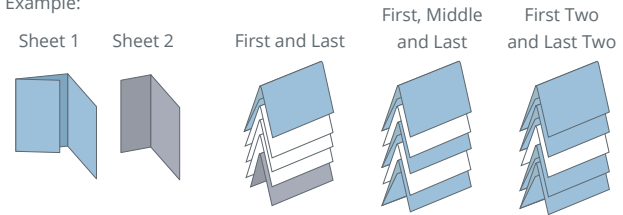

\*Production speed changes depending on the number of sheets inserted.

#### WHEN FEEDING FROM HOF-400 (CF-400)

- Only one different size can be inserted when the sheets are fed from the HOF-400 (CF-400).

### STITCHER HEAD

- The stitcher head is selectable from either of the standard stitcher heads (No.28 to No.24, thickness: 0.4 to 0.6 mm / 0.016" to 0.024") or the stitcher head for thick wire (No.26 to No.24, thickness: 0.5 to 0.6 mm / 0.02" through 0.024").



When B-40S installed

- Four stitches and three stitches are available as options.

\*The B-40C kit for three stitches or the B-40S kit for four stitches is required.

### CC40-06/08/10/12 CENTER-CUT UNIT

- Two-up production is available by installing the center-cut unit.
- Four types of units; cutting width 6 mm / 0.24", 8 mm / 0.31", 10 mm / 0.39", and 12 mm / 0.47".

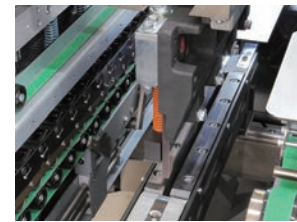

### LOOP STITCHING KIT

- Loop stitching is available by installing the loop stitching kit with the stitch head.

\*The stopper for loop stitching is required for the trim section.

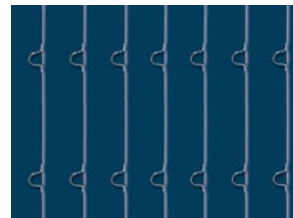

### WDD-SPF50 / WDU-SPF50 WIRE DRIVE DEVICE

- The wire drive device adjusts the length of wires according to the thickness of the booklet.
- WDU-50 is required for the three and four stitch option.

\*Two sets of WDU-SPF50 are required for four stitches.





# ADDITIONAL OPTIONS.

## Performance Enhancing Options.

### HP-40S + HP-05K/C05K/06K/C06K HOLE PUNCH UNIT

- High speed two-hole punching can be performed in-line for efficient production.
- HP-05K (5 mm hole), HP-06K (6 mm hole) and one-hole punch unit (for fore-edge) are available.

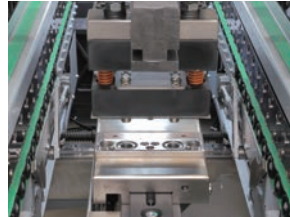

### PK-30 PRESET KICKER

- According to a preset number input on the touchscreen, a booklet is skewed to identify and separate the end of a series.

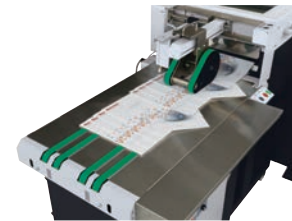

### HTS-TD40 THICKNESS DETECTOR

- The HTS-TD40 detects booklets with incorrect thickness and ejects them to the mis-feed tray.  
\*The sensor turns off automatically for variable thickness production.



### TB-30 TRIMMINGS BLOWER

- The TB-30 ejects the trim waste from the HTS-50 by air.



### HTS-AR40 TRANSPORT ROLLERS

- The upper transport rollers of the delivery conveyor are automatically set to match the finished size of the booklet.

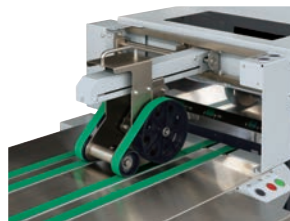

### HTS-ECV40 DELIVERY CONVEYOR

- The 1m conveyor extends the booklet capacity of the conveyor and is suitable for longer production runs.

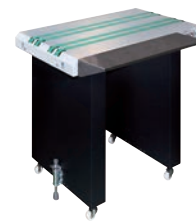

# OPTIONS.

## Options for iCE STITCHLINER Mark IV.

	NAME	MODEL	DESCRIPTIONS
Fold Section	Press Roller 70	-	Urethane fold roller
	Six Page Fold Program	SL6PS-40	Software for different length sheet insertion
Stitch Section	Stitcher Head Option for Four Stitching	B-40S	A set of two stitcher head attaching parts (Stitcher head and clincher are not included.)
	Stitcher Head Optional Parts for Center Stitching	B-40C	Stitcher head attaching parts (Stitcher head and clincher are not included.)
	Centering Device	CD-30S	For four stitching and center stitching
	Clincher	-	For four stitching (B-40S) and center stitching (B-40C)
	52/8S Stitcher Head (for thick wire No.24 through 28)	-	Standard stitcher head: Wire thickness 0.4 through 0.6 mm
	52/8S Stitcher Head (for fine wire No.26 through 30)	-	Stitcher head for fine wire: Wire thickness 0.4 through 0.5 mm
	52/8S Head Parts for thick wire	-	For one stitcher head: Wire thickness 0.4 through 0.6 mm
	52/8S Loop Stitching Parts	-	For one stitcher head: Wire thickness 0.5 mm through 0.6 mm The stoppers for loop stitching are also required for the HTS-50.
	43/6S Stitcher Head (for thick wire No.24 through 26)	-	For thick wire: Thickness 0.5 through 0.6 mm
	43/6S Stitcher Head (for fine wire No.26 through 28)	-	For fine wire: Thickness 0.4 through 0.5 mm
	43/6S Head Parts for Thick Wire	-	For one stitcher head
	43/6S Loop Stitching Parts	-	For one stitcher head: Wire thickness 0.5 through 0.6 mm The stoppers for loop stitching are also required for the HTS-50.
	Wire No. 24	-	0.60 mm or 0.024"
	Wire No. 25	-	0.55 mm or 0.022"
	Wire No. 27	-	0.45 mm or 0.018"
	Wire No. 28	-	0.40 mm or 0.016"
	Wire No. 29	-	0.375 mm or 0.015"
	Wire No. 30	-	0.35 mm or 0.014"
	Wire Drive Device	WDD-SPF50	Wire control device for automatic wire adjustment (For two stitching)
	Additional Wire Drive Unit	WDU-SPF50	Additional wire control unit for three or four stitching. (2 pcs required for four stitching)
Pole Lamp	TL-SPF50	Status indicator light	
Trim Section	Additional Stoppers for Top-Bottom Trim Section	-	For loop stitching (Three types of additional stoppers)
	Booklet Press Plate for Fore-edge Trim Section	CP40-FS	For small size booklets
	Booklet Press Plate for Top-bottom Trim Section	CP40-TS	For small size booklets
	Center-Cut Device (6 mm or 0.24" Width)	CC40-06	Cutting Width 6 mm or 0.24" (Maximum booklet thickness: 3 mm or 0.12")
	Center-Cut Device (8 mm or 0.31" Width)	CC40-08	Cutting Width 8 mm or 0.31" (Maximum booklet thickness: 4 mm or 0.16")
	Center-Cut Device (10 mm or 0.39" Width)	CC40-10	Cutting Width 10 mm or 0.39" (Maximum booklet thickness: 4 mm or 0.16")
	Center-Cut Device (12 mm or 0.47" Width)	CC40-12	Cutting Width 12 mm or 0.47" (Maximum booklet thickness: 4 mm or 0.16")
	Punch Base Unit	HP-40S	Common parts in the punch hole diameter 5 mm or 6 mm
	Punch Unit (5 mm or 0.197" hole)	HP-05K	For two holes: Punch hole diameter 5 mm or 0.197"
		HP-C05K	For one center hole: Punch hole diameter 5 mm or 0.197"
	Punch Unit (6 mm or 0.236" hole)	HP-06K	For two holes: Punch hole diameter 6 mm or 0.236"
		HP-C06K	For one center hole: Punch hole diameter 6 mm or 0.236"
	Thickness Detector	HTS-TD40	The HTS-TD40 detects the booklets with abnormal thickness and eject in the misfeed tray of the HTS-50.
	Preset Kicker	PK-30	Separates the booklets by preset number on the delivery conveyor
	Delivery Conveyor	HTS-AR40	The upper delivery roller is automatically set according to the finished booklet size.
	Delivery Conveyor	HTS-ECV40	Extension conveyor to stack large number of booklets.
	Trimming Blower	TB-30	For ejecting the trim waste from the HTS-50 by air.
Paper Inserter	Paper Inserter	IM-30	Up to three sheets can be inserted into the middle of the booklet and beneath the top sheet. The IM-30 can be connected to the stitcher or can be used as a stand-alone.
	Conveyor for StitchLiner and IM-30	IM-CC	A conveyor to connect the IM-30 with the delivery section of HTS-50.
	Bypass Conveyor	IM-BC40	A conveyor which crosses over the IM-30 to transport the booklets to the conveyor of HTS-50.
	Error Insert Detector	IM-SD	An ultrasonic sensor detects that a front page is turned when a sheet is inserted in the front of the booklet.

# SPECIFICATIONS.

Machine Dimensions. (Unit: mm / inch)

## ICE STITCHLINER Mark IV + HOF-400

(Top View)

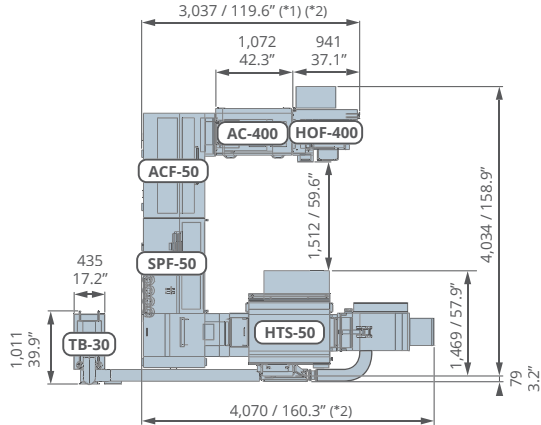

## ICE STITCHLINER Mark IV + VAC SERIES

(Top View)

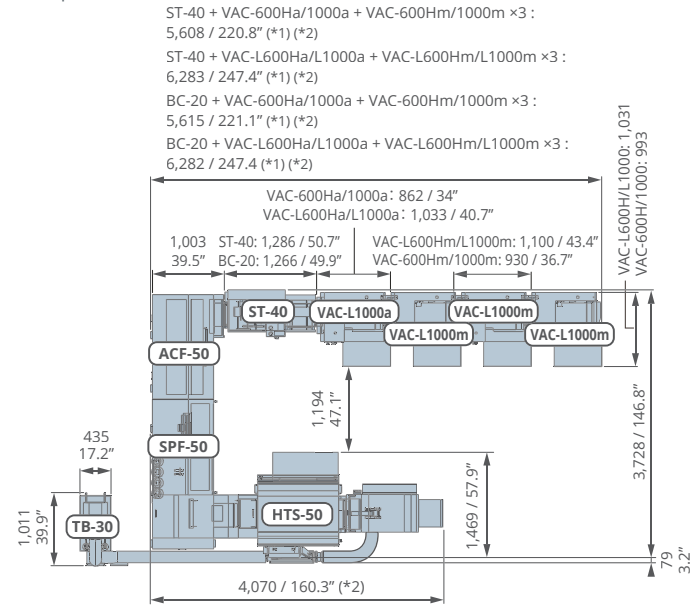

## ICE STITCHLINER Mark IV + VAC-1000 + HOF-400

(Top View)

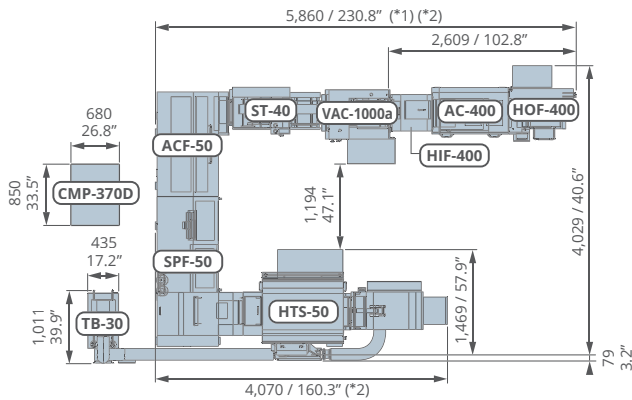





\*1 The dimension contains the connecting parts and overlapped parts between each unit.

\*2 The dimension varies depending on the configuration of optional devices. The WDD-SPF50 and HTS-ECV40 require additional space on the system layout:

- 154 mm (6.1") is added for the WDD-SPF50 wire drive unit
- 1,003 mm (39.5") is added for the HTS-ECV40 delivery conveyor

## ICE STITCHLINER Mark IV

<b>Finishing Type</b>	Saddle Stitch, Fold and Trim
<b>Sheet Size</b> (Width x Length)	Portrait Max. 356 x 508 mm or 14.015" x 20.000" Landscape Max. 267 x 610 mm or 10.510" x 24.015" Min. 140 x 194 mm or 5.515" x 7.640" *There is a limit if the top-bottom size is smaller against the fore-edge size. 
<b>Untrimmed Booklet Size</b> (Width x Length)	A3, JIS B4, A4, JIS B5, A5 11.25" x 17.25", 11" x 17", 10.25" x 9.75", 8.75" x 11.25", 8.5" x 11", 5.5" x 9.75" Portrait Max. 356 x 254 mm or 14.015" x 10.000" Landscape Max. 267 x 305 mm or 10.510" x 12.005" *Max. 356 mm x 305 mm or 14.015" x 12.005" can be finished depending on substrate weight and condition. Min. 140 x 97 mm or 5.515" x 3.820" *Depending on the sheet weight, sheet thickness, booklet thickness or grain direction, the booklet spine may be marked by the transport belts, or the booklet may not be arranged properly on the delivery conveyor. (In this case, the kicker may not be used.) A4, A4E, JIS B5, A5, JIS B6, A6 11" x 8.5", 8.5" x 11", 8.5" x 7", 8.5" x 5.5", 4.75" x 4.75" 2-up, 4.75" x 4.75"
<b>Finished Booklet Size</b> (Width x Length)	Portrait Max. 352 x 252 mm or 13.855" x 9.920" Landscape Max. 263 x 303 mm or 10.350" x 11.925" *Max. 352 mm x 303 mm or 13.855" x 11.925" can be finished depending on substrate weight and condition. Min. 120 (*) x 85 mm or 4.725" x 3.350" *Minimum width when each of the center guides is installed in the trim section: Small Center Guide: 147 mm or 5.790" Medium Center Guide: 204 mm or 8.035" Large Center Guide: 279 mm or 10.985" 
<b>Sheet Weight Range</b>	Normal Paper: 52.3 to 350 gsm Coated Paper: 73.3 to 350 gsm
<b>Fold Thickness</b>	Max. 2 mm or 0.075" (Thickness of one block)
<b>Stitch Thickness</b>	Max. 5 mm or 0.195" (Booklet thickness 10 mm or 0.390") (About 50 sheets of Normal Paper 81.4 gsm) When Doing Loop Stitching: Max. 3 mm or 0.118" (Booklet thickness 6 mm or 0.236")
<b>Stitch Distance</b>	<b>Two Stitch</b> With Centering Device: 64 to 176 mm or 2.520" to 6.925" Without Centering Device: 53 to 176 mm or 2.090" to 6.925" <b>Three Stitch (Requires the B-40C kit)</b> When using the standard head blocks and center block: - With Centering Device Stitch Distance: Right and Left 64 to 88 mm or 2.520" to 3.460" Overall 128 to 176 mm or 5.040" to 6.925" - Without Centering Device Stitch Distance: Right and Left 53 to 88 mm or 2.090" to 3.460" Overall 106 to 176 mm or 4.175" to 6.925" In case of using the outside head blocks for four sticher heads and center block: Stitch Distance: Right and Left 106 to 120 mm or 4.175" to 4.720" Overall: 212 to 240 mm or 8.350" to 9.445" (Independent of centering device) *When doing three stitches, this cannot be done in the range where the overall measurement is 176.1 to 211.9 mm or 6.935" to 8.340". <b>Four Stitch (Requires the B-40S kit)</b> - With Centering Device Stitch Distance: Inside 64 to 112 mm or 2.520" to 4.405" Right and Left: 64 to 88 mm or 2.520" to 3.460" Overall: 192 to 240 mm or 7.560" to 9.445" - Without Centering Device Stitch Distance: Inside 53 to 134 mm or 2.090" to 5.275" Right and Left: 53 to 93.5 mm or 2.090" to 3.680" Overall: 159 to 240 mm or 6.260" to 9.445"
<b>Stitch Heads</b>	Standard Equipment: Two sticher heads Option: Additional sticher heads for three or four stitches *The B-40C kit for three stitches or the B-40S kit for four stitches is required.

<b>Stitching Wire</b>	Standard: 0.5 mm (No.26) Option: Wire from of 0.4 to 0.6 mm in diameter can be installed on the standard sticher heads.
<b>Trim Width</b>	Fore Edge: Max. 25.4 mm or 1.000" Min. 2 mm or 0.080" Top and Bottom: Max. 25.4 mm or 1.000" Min. 2 mm or 0.080"
<b>Trim Thickness</b>	Max. 10 mm or 0.390" *This may be limited depending on sheet weight range and the number of sheets.
<b>Production Speed</b>	Max. 6,000 booklets per hour (A4 Portrait finished from A3 sheets) Max. 5,300 booklets per hour (A4 Landscape) *The production speed is affected by the operation mode and paper condition. The production speed will be limited depending on the number of connected towers when the VAC-1000/600H/L1000/L600H is connected. Four Towers: 5,000 sets per hour Five Towers: 4,500 sets per hour Six Towers: 4,000 sets per hour Other than the condition described above, the upper limit of production speed changes depending on the number of bins that are used, the number of overlap of sheets, the belt speed and the block feed setting.
<b>Voltage/Frequency</b>	3-phase 200-230 V, 50 / 60 Hz (No transformer supplied with the machine) 3-phase 380 / 400 / 415 V, 50 / 60 Hz (The transformer is supplied with the machine to step down to 200 V.)
<b>Machine Dimensions</b>	3,601 (W) x D 4,062 (D) x 1,350 (H) mm or 141.8" x 160.0" x 53.2"
<b>Center Cut (Option)</b>	Gutter Width: 6 mm (0.240") / 8 mm (0.315") / 10 mm (0.395") / 12 mm (0.475") Booklet Thickness: 4 mm (0.155") or thinner, half of gutter width or less Booklet Size Before Cut: Width 190 to 356 mm or 7.485" to 14.015" Length 85 to 220 mm or 3.350" to 8.660" <b>Four stitches - gutter width 6 mm or 0.235"</b> Booklet Size before Top and Bottom Trimming and after Fore-Edge Trimming: Width 214.5 to 356 mm or 8.445" to 14.015" Length 85 to 220 mm or 3.350" to 8.660" Finished Booklet Width: 100 to 173 mm or 3.940" to 6.810" <b>Four stitches - gutter width 12 mm or 0.475"</b> Booklet Size before Top and Bottom Trimming and after Fore-Edge Trimming: Width 211.5 to 356 mm or 8.330" to 14.015" Length 85 to 220 mm or 3.350" to 8.660" Finished Booklet Width: 94 to 170 mm or 3.700" to 6.690" <b>Two stitches or without stitch - gutter width 6 mm or 0.235"</b> Booklet Size before Top and Bottom Trimming and after Fore-Edge Trimming: Width 190 to 356 mm or 7.485" to 14.015" Length 85 to 220 mm or 3.350" to 8.660" Finished Booklet Width: 90 to 173 mm or 3.545" to 6.810" <b>Two stitches or without stitch - gutter width 12 mm or 0.475"</b> Booklet Size before Top and Bottom Trimming and after Fore-Edge Trimming: Width 196 to 356 mm or 7.720" to 14.015" Length 85 to 220 mm or 3.350" to 8.660" Finished Booklet Width: 90 to 170 mm or 3.545" to 6.690"  The center-cut option cannot be selected under the following conditions: - If the optional punch is selected - If the center stitch is selected - If the top and bottom trim function is turned off
<b>Punch (Option)</b>	Hole Diameter: 5 mm or 0.197" / 6 mm or 0.236" Hole Position: Two Holes at 8 to 16 mm from spine, 80 mm pitch One Hole at 5 to 15 mm from fore edge, centered Booklet Thickness: 3 mm (0.115") or thinner, half of hole diameter or less  The punch option cannot be selected under the following conditions: - If the center-cut is selected - If the top and bottom trim function is turned off Booklet Size Before Top and Bottom Trimming: Width 254 to 356 mm or 10.000" to 14.015" Length 85 to 220 mm or 3.350" to 8.660" Finished Booklet Width: 250 to 352 mm or 9.850" to 13.858"

\*The machine design and specifications are subject to change without any notice.

\*Specifications may vary depending on the job, paper quality, environmental influences, and various other factors. Please do a test run before starting production.

# ROLL TO SADDLE STITCH SOLUTION.

Roll to saddle stitch solution for inline or near-line with continuous feed digital presses.

## ICE STITCHLINER Mark V



### HIGH PRODUCTIVITY

Up to 6,000 high quality booklets can be produced per hour while maintaining the speed of the unwinder. Non-stop and stable production is achieved on a wide variety of substrates and formats including booklets with thin sheets and flap covers.

### RELIABLE PRODUCTION

Optional quality control features such as the code readers for mis-loading detection, page order checking, and cover and book block matching. The barcode verification system enhances reliability of production quality by checking up to six verification points in the system.

### VARIABLE THICKNESS PRODUCTION

True end to end automation for variable thickness production. Variable stitch length and balance adjustment combined with variable thickness transport adjustment through the trimmer.

### FLEXIBLE SHEET INSERTION

Optional cover feeder CF-50D enables flexible insertion of various substrates and formats of folded and cut sheets. The scoring feature provides high quality scoring on covers to the covers for tighter folding quality.

■ Colored sheets are cover or insert sheets from the cover feeder.



Cover sheet    Single sheet in the middle    Single sheet in the bottom    Multiple sheets \*Up to 3 sheets can be inserted with 3 towers.

### Configuration of ICE STITCHLINER Mark V

#### SPF-50D Saddle-Stitcher

Uniquely designed separation and stitching system achieves precise sheet accumulation and high quality stitching at high speed.

#### IFU-50D Interface Unit

Each sheet is scored one by one after precise sheet registration to reduce cracking of the spine and tighter folding quality. Adjustable infeed height\* offers greater connectivity with a variety of cutter and unwinder models. \*720 to 1,110 mm (28.4 to 43.7")



#### ACF-50D Accumulator and Folder

Newly designed sheet transport mechanism brings consistent and high folding quality for sharper and tighter booklets with improved accuracy.

#### HTS-50 Three-Knife Trimmer

All the settings are done automatically on the fly for variable thickness production. Uniquely designed 4 side jogging achieves accurate trimming quality with 1-up or 2-up production.

#### CF-50D Cover Feeder **OPTION**

A wide range of different cut-sheet substrates and formats\* can be merged with sheets from the cutter. The CF-50D can also function as an offline sheet feeder. \*Sheet length needs to be the same with cut sheets.

## Tracking System

Tracking system verifies the book ID, total number of pages, and page order to check the matching of book block and cover, and transportation of booklet. The tracking results are saved to the PC.

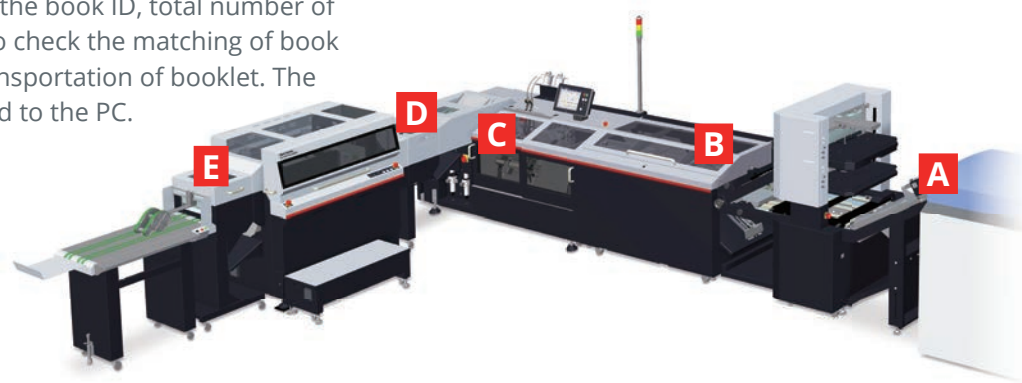

### A Reading Barcode on Book Block

The barcode on each sheet is read at the infeed section of IFU-50D. This detects any mixing of different jobs, checks the total number of sheets for a book block, and page order.

### B Checking Cover and Book Block Matching

When the CF-50D is connected, an additional (optional) code reader is available to check the matching of the cover (sheets or signature) inserted by the CF-50D and the sheets transported by the IFU-50D.

### C Checking Number of Sheets for Separation

Barcode reader verifies if the book block is separated properly.

### D Checking Ejected and Transported Books

Code reader checks that bad booklets are ejected and only good booklets are transported to the trimmer. Error record of ejected booklets due to errors such as skewed folding are reported on the PC.

### E Final Check

An additional (optional) code reader checks that bad booklets are ejected and only good booklets are transported to the delivery section. Error record of ejected booklets due to errors such as a thickness error are reported on the PC.

## SPECIFICATIONS FOR ICE STITCHLINER Mark V

<b>Finishing Type</b>	Saddle Stitch, Fold and Trim
<b>Sheet Size</b>	<p><b>Width X Length</b></p> <p>Portrait Max. 508 x 356 mm or 20.000" x 14.015" Landscape Max. 610 x 267 mm or 24.015" x 10.510" Min. 194 x 140 mm or 7.640" x 5.515" *There is a limit if the top-bottom size is smaller against the fore-edge size.</p> <p>A3, JIS B4, A4, JIS B5, A5 11.25" x 17.25", 11" x 17", 10.25" x 9.75", 8.75" x 11.25", 8.5" x 11", 5.5" x 9.75"</p>
<b>Booklet Size</b>	<p><b>Untrimmed Booklet Size</b></p> <p>Portrait: Max. 356 x 254 mm or 14.015" x 10" Landscape: Max. 267 x 305 mm or 10.510" x 12.005" Min. 140 x 97 mm or 5.515" x 3.820" (*1) *Max. 356 mm x 305 mm or 14.015" x 12.005" can be finished depending on substrate weight and condition.</p> <p>A4, A4E, JIS B5, A5, JIS B6, A6 11" x 8.5", 8.5" x 11", 8.5" x 7", 8.5" x 5.5", 4.75" x 4.75" 2-up, 4.75" x 4.75"</p> <p>*1: Depending on the sheet weight, sheet thickness, booklet thickness or grain direction, the booklet spine may be marked by the transport belts, or the booklet may not be arranged properly on the delivery conveyor. (In this case, the kicker may not be used.)</p> <p><b>Finished Booklet Size</b></p> <p>Portrait: Max. 352 x 252 mm or 13.855" x 9.920" Landscape: Max. 263 x 303 mm or 10.350" x 11.925" Min. 120 (*2) x 85 mm or 4.725" x 3.350" *Max. 352 mm x 303 mm or 13.855" x 11.925" can be finished depending on substrate weight and condition.</p> <p>*2: Minimum width when each of the center guides is installed in the trim section: Small Center Guide: 147 mm or 5.790" Medium Center Guide: 204 mm or 8.035" Large Center Guide: 279 mm or 10.985"</p>

<b>Sheet Weight Range</b>	Roll Paper	Normal Paper: 52.3 to 209 gsm Coated Paper: 73.3 to 209 gsm Allowable Curl: +/- 8 mm or +/-0.31"
	Cover Sheet	Normal Paper: 52.3 to 350 gsm Coated Paper: 73.3 to 350 gsm *These may be limited depending on the sheet size, sheet weight range and grain direction of the sheet.
<b>Fold Thickness</b>	Max. 2 mm or 0.078" (Thickness that can be folded)	
<b>Stitch Thickness</b>	Max. 5 mm or 0.195" (About 50 sheets of Normal Paper 81.4 gsm)	
<b>Stitching Wire</b>	Standard: 0.5 mm (No.26) (Wire from of 0.4 to 0.6 mm in diameter can be installed on the standard stitcher heads.)	
<b>Trim Width</b>	Fore Edge	Max. 25.4 mm or 1.000" Min. 2 mm or 0.080"
	Top and Bottom	Max. 25.4 mm or 1.000" Min. 2 mm or 0.080"
<b>Trim Thickness</b>	Max. 10 mm or 0.390" (This may be limited depending on sheet weight range and the number of sheets.)	
<b>Voltage/Frequency</b>	3-phase 200/208/220/230 V, 50/60 Hz (*3) 3-phase 380/400/415 V, 50/60 Hz (*4) *3: No transformer supplied with the machine *4: The transformer is supplied with the machine to step down to 200 V.	

\*The machine design and specifications are subject to change without any notice.

\*Specifications may vary depending on the job, paper quality, environmental influences, and various other factors. Please do a test run before starting production.

**MORE AT**  
**HORIZON.CO.JP**



**Horizon**

Horizon International Inc.

1601 Asahi, Shinasahicho, Takashima,  
Shiga, 520-1501, Japan  
Phone : +81-740-25-4570  
Fax : +81-740-25-5820  
[www.horizon.co.jp](http://www.horizon.co.jp)

Distributed by

 **STANDARD**

Standard Finishing Systems

10 Connector Road, Andover,  
MA 01810  
Phone : 877-404-4460 / 978-470-1920  
Fax : 978-470-2771  
[www.standardfinishing.com](http://www.standardfinishing.com)