

Automatic Uniform Carton Sealer

Model:

PP-558F

This heavy-duty machine seals the top & bottom of boxes simultaneously

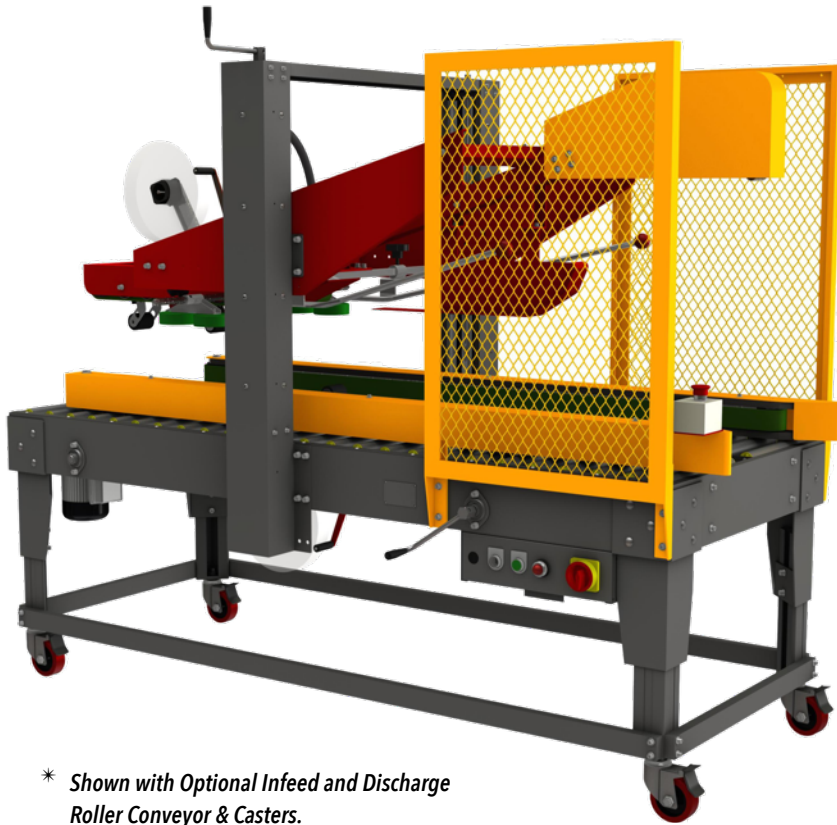

* Shown with Optional Infeed and Discharge Roller Conveyor & Casters.

Automatic Top Flap Folding with Side & Top Drive Belt for Positive Grip Pressure

- Fully-Automatic Uniform Carton Sealer with Automatic Top Flap Folding and Easy Manual Carton Size Adjustment.
- Side Drive Belt Design with 2 Top Drive Belts and 2 Side Drive Belts.
- Featuring Our New "Piranha" Tape Head with "Easy Thread Design."
- Machine Comes Complete with Adjustable Height Legs, Power Cord and Plug.



Automatic Box Folding of Major and Minor Top Flaps



Heavy Duty Top Drive and Bottom Side Drive Belts For Positive Grip Pressure



New "Piranha" Tape Head Features An Easy Thread Design with Optimizer Arm.

PP-558F CARTON SEALER

This operator-free machine can be fed from a production line directly into the PP-558F where the machine will fold the top flaps and automatically tape closed. The PP-558F applies a single tape strip to both the top and bottom of the case simultaneously. This four belt drive design is a heavy duty versatile machine designed for dependable performance and easy operation. The PP-558F can be easily adjusted in only seconds to process a different size carton.

STANDARD FEATURES:

- Piranha Tape Head with "Easy Thread" Design
- Interchangeable Tape Heads
- Side Pressure Rollers to Close Box Top
- 2 Side Drive Belts
- 2 Top Drive Belts
- Fully Adjustable Legs

OPTIONAL FEATURES:

- 3" (72mm) Tape Heads
- Infeed Conveyor
- Exit Conveyor
- Stainless Steel Frame
- Heavy Duty Locking Casters

CARTON SIZE: LENGTH: 8" min. to 21.5" max.
 WIDTH: 8" min. to 20" max. (8.9" on 3" Head)
 HEIGHT: 4.75" min. to 20" max.

MACHINE SIZE: 80"L x 35"W x 64"H

MACHINE SPEED: 75ft/min Up to 15 cartons per minute. Production rate depends on carton size and operator dexterity

ELECTRICAL: 110 Volt, 1 Phase, 10 Amp

WEIGHT: 715 lbs. Shipping Weight: 775 lbs.

MAX BOX WEIGHT: 75lbs.

TAPE HEAD SPECS: 2" (48mm) Wide - 1,000 yard or 1,500 yard rolls.

WARRANTY: 1 Year Limited Warranty

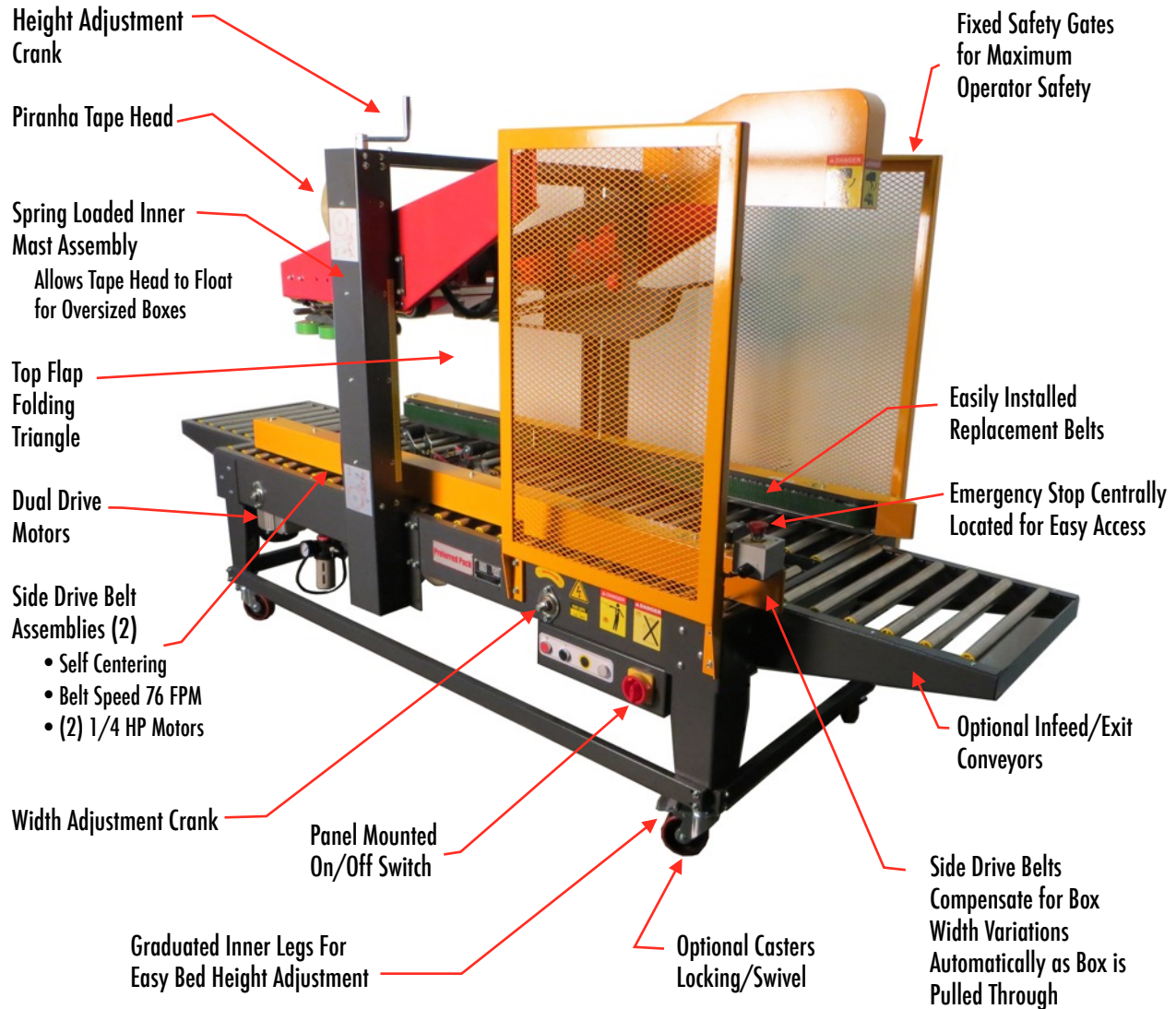
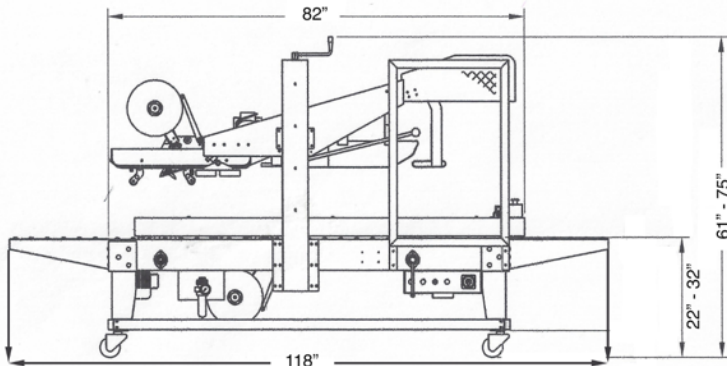

Top Flap Compression Roller to Keep Box Top Closed



Piranha Tape Heads with Optimizer Arm



Emergency Stop Switch



Air Required for Pneumatic Minor Flap Closer